

RE10TC

Temperature Control Module

Operating manual

Edition 02/2003

Industrial automation

Elincom Group

 European Union: www.elinco.eu

 Russia: www.elinc.ru

Note

This operating manual cannot take into consideration every conceivable case of installation, operation and possibly occurring faults.

If you need further information, or should there be specific problems, which are not treated in detail in this operating manual, please get in touch with RESOTEC GmbH or concerned sales office in your area or one of the sales representatives of MITSUBISHI ELECTRIC EUROPE B.V.

This document may not be passed on or copied, its contents may not be used for commercial purpose or reported without written approval.
Non-compliance shall invite claims for damages.

©Resotec GmbH 2001 All rights reserved

RE10TC Temperature Control Module

Article no.: 138956

Version			Changes / additions / corrections
A	07/2001	pdp-dk	—
B	03/2002	pdp-dk	Default values for operation modes in table 3.11 on page 3-10.
C	02/2003	pdp-dk	Chapter 2.1.1: Note (BFM #340) Chapter 2.2.3: Note (BFM #357) Chapter 2.3.2: Function of heating current monitoring Chapter 2.3.3: Function of leaking current monitoring Chapter 3-2: Meaning of BFM #45 Chapter 3-9: Unit for BFM #291 and BFM #292 New chapters 3.2.1 and 3.2.2 Chapter 3.2.7: Explanation for BFM #29 Chapter 3.2.8: Explanation for BFM #45 Chapter 3.3.1: Note (activating the set values) Chapter 3.3.2: "Bit 0" changed to "Bit 9" Chapter 3.3.8: Definition for „Duty cycle when a sensor error is detected“ Chapter 3.3.9: Headline, Description Chapter 3.3.10: Description Chapter 3.3.12: Addition of values for "cooling constant" und „cooling constant starting point“ Chapter 5: Addition of programming examples

Safety notes

General instructions

Read the respective chapter on operation before using a specific function for the first time. This would help you in avoiding operating errors and it protects you and the operating system from possible damage as a result of improper use.

Never undertake repair work on the device yourself. Inappropriate handling entails the danger of an electrical shock. Leave the repair work to trained experts.

Qualified personnel

The present manual includes information necessary for the application and use of the product, the way it is meant to be used. It is directed at technically qualified personnel, who have the relevant knowledge in the field of automation technology.

Qualified personnel are persons,

- who, as project planning personnel, are well-versed with the safety concepts of the automation technology,
- who, as operating personnel, are instructed in handling the automation equipment and who have attended an induction course in the operation of the device,
- who, as commissioning and service personnel, have been trained to repair automation equipment of this type and who are authorized to start-up, earth and mark electric circuits and devices in compliance with the safety engineering standards.

Detailed knowledge and technically correct implementation of the installation guidelines, safety notes and functions, described in this handbook, are prerequisites for operational safety.

Safety design of the entire system

Since the described components and devices can be installed in various areas and systems, it is absolutely essential to incorporate their functions and the corresponding safety notes in the safety concept of the entire system.

Intended use

Handling specifications and safety notes

The device should be installed only according to the product information and technical description. The relevant safety standards should be followed for the development, manufacture, inspection and documentation of articles. Normally, there is no product related risk of material damage or personal injury when handling specifications and safety-related notes are followed.

Safety of the product requires proper transport, storage, installation and operation.

Only qualified personnel may operate the product.

Make sure that the supply voltage is switched off before connecting or disconnecting the temperature control module.

In order to prevent damage to the electronics system, the device should not be switched on when there is dew formation in the device. On shifting from a cold to a warm place, due to the risk of dew formation, temperature equalization should therefore take place two hours before start-up.

See to it that the device is not covered, in order to ensure air-circulation necessary for cooling.

Do not allow the device to be in direct sunlight for a long time or in any other place where high temperatures could exist (for example, radiators).

Do not expose the operating unit to humidity or rain.

Only shielded conductors are permissible for any signal connection.

Signal lines should not be lead with high tension lines in the same cable duct.

No liability is accepted for malfunctioning and defects resulting from use of self-made cables or those of third party manufacturer.

The supply voltage should lie only within the given voltage range .

Connect the earth connection of the device with the earth of the control cabinet.

Warning notes

The individual instructions have the following meaning:



DANGER:

Means that there is a danger to the life and health of the user due to electrical current, if the related safety measures are not undertaken.



WARNING:

Means a warning against possible damage to the device or other assets as well as against faulty settings, if the related safety measures are not undertaken.

Maintenance



RESOTEC and Mitsubishi products may be maintained only by RESOTEC or Mitsubishi service department or authorized persons and companies.

Original modules and components of RESOTEC or Mitsubishi should be used exclusively.

The replacement of modules should be carried out by qualified personnel.

Standard components like for example, safety devices should correspond to the specified values.

Contents

1	Introduction	
1	Introduction	1-1
2	Functions	
2.1	PID control	2-1
2.1.1	Self optimisation (pretuning)	2-3
2.2	Measuring of temperatures	2-5
2.2.1	Configuration of the analog inputs	2-5
2.2.2	Monitoring of the temperature sensors	2-5
2.2.3	Alarms	2-6
2.3	Measurement of the heating current	2-8
2.3.1	Measurement method	2-8
2.3.2	Monitoring of the heating current	2-8
2.3.3	Monitoring of the leakage current	2-9
3	Buffer Memory	
3.1	Buffer memory list	3-1
3.1.1	Actual values	3-1
3.1.2	Set values	3-5
3.1.3	Control flags	3-10
3.2	Details of the real values	3-11
3.2.1	Actual temperatures (BFM #0 to BFM #9)	3-11
3.2.2	Duty cycle (BFM #10 to BFM #19)	3-11
3.2.3	State of the digital outputs (BFM #20 and BFM #21)	3-12
3.2.4	State of the alarms and warnings (BFM #22 to BFM #25)	3-12
3.2.5	Flags: Sensor fault (BFM #26)	3-13
3.2.6	Status flags of the RE10TC (BFM #27)	3-13
3.2.7	Error flags of the RE10TC (BFM #29)	3-14
3.2.8	Measured value is outside the input range (BFM #45)	3-14
3.2.9	Error flags: Heating current (BFM #46)	3-14
3.2.10	State of the self optimisation (BFM #50 to BFM #59)	3-15
3.3	Details of the set values	3-16
3.3.1	Set values for temperatures (BFM #120 to BFM #129)	3-16
3.3.2	Set values for temperatures in stand-by mode (BFM #130 to BFM #139)	3-16
3.3.3	Limits and warnings (BFM #140 to BFM #179)	3-16

3.3.4	Integral time T _I (BFM #200 to BFM #209)	3-17
3.3.5	Derivative time T _D (BFM #210 to BFM #219)	3-17
3.3.6	Shortest ON time for heating and cooling (BFM #220 to BFM #239) . .	3-17
3.3.7	Temperature offset (BFM #260 to BFM #269)	3-17
3.3.8	Duty cycle when a sensor error is detected (BFM #270 to BFM #279)	3-17
3.3.9	Monitoring time for temperature sensor short circuit monitoring (BFM #280 to BFM #289)	3-18
3.3.10	Leading values (BFM #290 to BFM #292)	3-18
3.3.11	Switching threshold for changing the PID constants (BFM #293)	3-18
3.3.12	Cooling constant & switching threshold for cooling constant (BFM #305 to BFM #324)	3-18
3.3.13	Monitoring of the lower limits and warnings (BFM #325)	3-19
3.3.14	Control of the digital outputs by the PLC (BFM #327 and BFM #328) .	3-19
3.3.15	Operation mode (BFM #330 to BFM #339)	3-20
3.3.16	Control flags from the CPU of the PLC (BFM #340)	3-21
3.3.17	Controller ON/OFF (BFM # 341)	3-21
3.3.18	Monitoring of limits ON/OFF (BFM #342 to BFM #345)	3-22
3.3.19	Monitoring of heating currents ON/OFF (BFM #347)	3-22
3.3.20	Watchdog (BFM #348)	3-22

4 Installation

4.1	Name of each part	4-1
4.2	Installation method	4-2
4.3	Wiring	4-3

5 Programming

5.1	Initial settings	5-1
5.1.1	Detection of RE10TC errors	5-2
5.1.2	Writing to the control word BFM #340	5-3
5.2	PID control	5-4
5.2.1	Stand-by mode	5-6
5.2.2	Self optimisation (pretuning)	5-7
5.3	Monitoring of the sensors	5-9
5.4	Alarms	5-9
5.5	Monitoring of heating and leaking current	5-9

A Appendix

A.1 Dimensions A-1
A.2 General Specifications A-1
A.3 Performance Specifications A-2

Index

1 Introduction

The Temperature Control Module FX2N-RE10TC can control up to 10 temperature zones. Monitoring of the connected thermocouples for broken wire and short circuits will be performed. The measured input from the thermocouples is converted into a linear curve and can be read by the PLC. User set upper and lower limits for each temperature control circuit are monitored by the RE10TC.

Additionally the module offers a heating current detection and an input for cold contact temperature compensation. Each of the 10 heating circuits is checked separately in a sequent order for the correct heating current. Thus only one current detector is required for ten heating circuits, reducing the overall costs for the system.

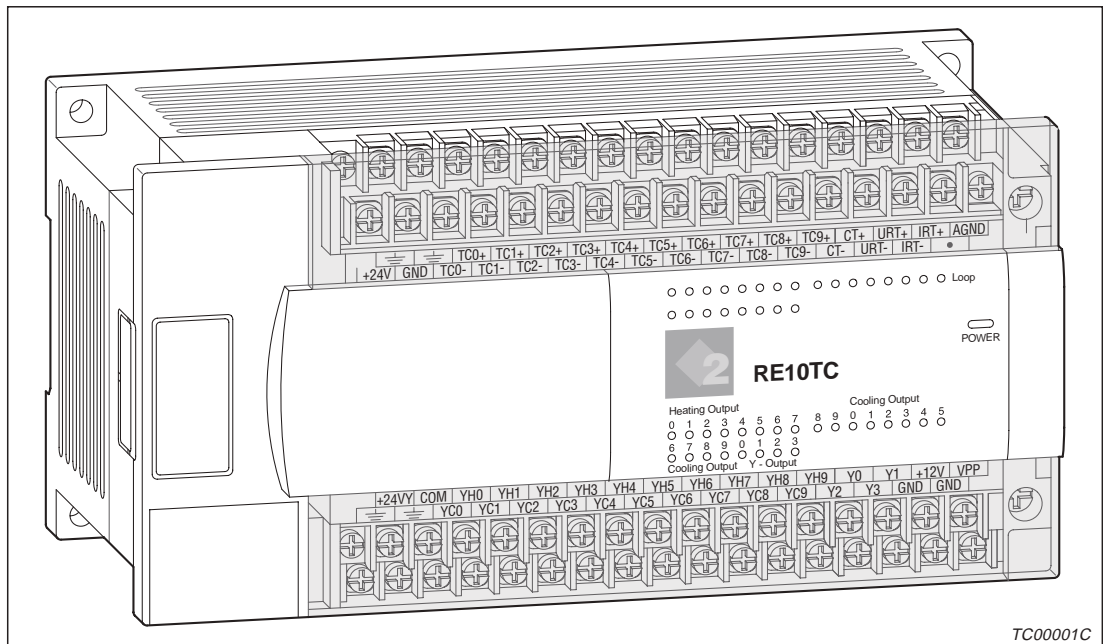

Fig. 1-1: Temperature Control Module FX2N-RE10TC

Features

- 10 independent two- or three-position PID temperature control circuits
- 10 independent thermocouple inputs for sensors type J, K, L and U
- Broken wire and short circuit detection
- All inputs can be used as voltage inputs as well (0 to 10 V DC)
- Integrated outputs for heating and cooling
- Analog input for heating current detection
- Heating current detection with one current detector for all 10 heating circuits
- Monitoring of upper and lower limits
- Self optimisation of the control circuits
- All functions are set by the software
- The power supply of the RE10TC is independent from the power supply of the PLC.
- Separate power supply for the digital outputs

2 Functions

Each setting and alarm in the RE10TC is written from or read to the CPU of the PLC via the buffer memory (BFM). In this chapter the functions of the temperature control module and the relevant areas of the buffer memory are described.

2.1 PID control

The RE10TC performs PID control of 10 temperatures. Setting of PID constants is performed using buffer memories. The integral and the derivative function of each controller can be switched off by setting the “I (integral time)” and the “D (derivative time)” to zero.

All temperature controllers can be used for two- or three-position control.

With two-position control the temperature is controlled by switching a heater ON or OFF.

With three-position control the temperature is controlled using three states: heating ON, cooling ON, heating and cooling OFF.

Each temperature controller has one analog input for the temperature sensor and two digital outputs for heating and cooling.

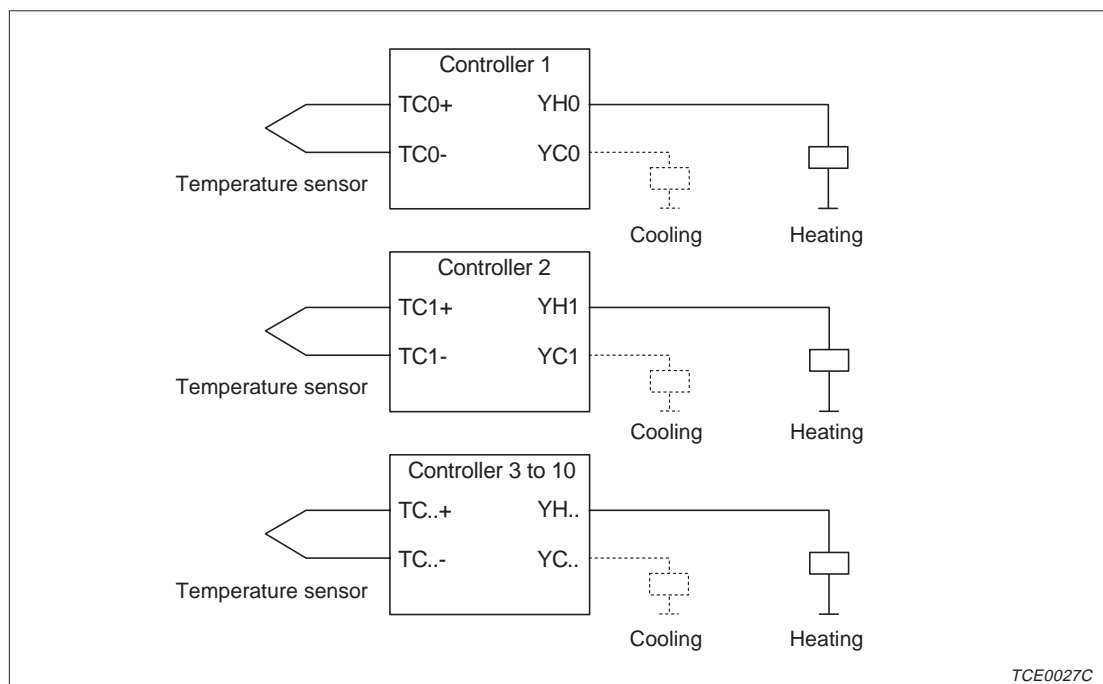

Fig. 2-1: Connection of analog inputs and digital outputs

If a controller is not active the corresponding digital outputs can be set by the PLC (refer to 3.3.10).

The temperatures of the ten heating zones can be lowered simultaneously by activating the stand-by mode. A set value for the desired temperature can be set for each controller. The regular set values become valid again with the end of the stand-by mode e.g. for heating up the machine.

Buffer Memory Address (decimal)	Name	Description	Real value/ Set value
0 to 9	Measured values	Scaled values from the analog inputs	Real values
10 to 19	Control output value	ON ratio of the outputs [%]	Real values
20 to 21	Output states	Shows whether the outputs are ON or OFF	Real values
27	Status flags of the RE10TC	Indication whether setpoints for stand-by mode are active or not	Real values
120 to 129	Set values	Set values for the temperatures	Set values
130 to 139	Set values for stand-by mode	Set values for the stand-by mode	Set values
180 to 189	Proportional band X _P (heating)	Settings for the temperature controllers	Set values
190 to 199	Proportional band X _P (cooling)		
200 to 209	Integral time T _I		
210 to 219	Derivative time T _D		
220 to 229	Shortest ON time (Heating)	Setting of the shortest ON time for the outputs	Set values
230 to 239	Shortest ON time (Cooling)		
290 to 292	Leading values	These settings are valid until switching (BFM #293).	Set values
293	Value for switching	Switching between master and regular settings	Set value
305 to 314	Cooling constant	Constant for water cooling	Set values
315 to 324	Starting point for cooling constant	Sets the actual value from which on the cooling constant will be valid	Set values
340	Control flags from CPU of PLC	Activation of setpoints, settings etc.	Set value
341	Controller ON/OFF	Selection of temperature controllers	Set value

Tab. 2-1: Buffer memory areas for temperature control

2.1.1 Self optimisation (pretuning)

With the self optimisation function the RE10TC automatically measures and calculates optimal PID constants. After completion of the self optimisation these constants can be transferred automatically or manually to the respective areas of the buffer memory for use as PID constants.

NOTE

The data stored in the buffer memory is lost when the power supply is switched off. Therefore it is recommended to save the PID constants found by self optimisation in the PLC. The PID constants must be written back to the buffer memory after switching on the power supply.

A flag in the operation mode settings is used to change the response time for pretuning.

Before starting the self optimisation, the following conditions must be fulfilled:

- The controllers of the heating zones that are to be optimised must be switched on.
- The heating system must be switched off.
- The desired temperature values of the heating zones that are to be optimised must be more than 120 °C. If a controller is defined as three position controller (heating/cooling), the desired temperature value for this zone must be at least 180 °C.
- The machine must be cold (actual values less than 40 °C).

During optimisation, the following must be particularly kept in mind:

- The desired temperature values may not be changed.
- No controllers may be switched on or off.
- No temperature limits or controller parameters may be changed.
- The heating system may not be switched on.
- The monitoring of the heating current must not be started.
- It is not allowed to write to the control word BFM #340

For each controller a word in the buffer memory informs about the state of the self optimisation (refer to 3.2.10). The following messages are possible:

- Prerequisites are being checked
- Configuration is not allowed
- Configuration is not optimum
- Configuration is running
- Determined parameters are not allowed
- Spare (internal use)
- Spare (internal use)
- Optimisation over (of the respective controller)
- Too small desired/actual value gap
- Very high actual temperature at the start
- Very high actual value fluctuation (2 °C during the step 1-6)
- An attempt to cool down follows
- No entry in the cooling table
- Sinking temperature while heating
- Very few values in the cooling table

There can be simultaneously multiple messages.

During the optimisation process the progress of the optimisation is stored as step number in the buffer memory. This step number is increased with every reading of the actual values.

After the self optimisation the PID constants found are stored in the buffer memory. When automatic copy of the constants is selected, the constants are transferred in the respective areas of the buffer memory as valid PID constants. When self optimisation without automatic copying is selected, the calculated PID constants can be read from the buffer memory by the PLC and transferred (e.g. after checking the values) to the buffer memory as valid parameters.

The following areas of the buffer memory of the RE10TC are connected to the self optimisation:

Buffer Memory Address (decimal)	Name	Description	Real value/ Set value
27	Status flags of the RE10TC	Indication of active self optimisation	Real value
50 to 59	State of the self optimisation	Informations about the progress of the self optimisation	Real value
60 to 69	Result of self optimisation: X _P (heating)	Calculated PID constants	Real value
70 to 79	Result of self optimisation: X _P (cooling)		Real value
80 to 89	Result of self optimisation: T _i		Real value
90 to 99	Result of self optimisation: T _d		Real value
100 to 109	Self optimisation step	Step number	Real value
330 to 339	Operation mode	Changing of the response to disturbance during self optimisation	Set value
340	Controlling flags from PLC CPU	Start of self optimisation with or without automatic copying of the calculated PID constants	Set value
341	Controller ON/OFF	Selection of the controllers which are to be optimized	Set value

Tab. 2-2: Buffer memory areas for self optimisation

2.2 Measuring of temperatures

2.2.1 Configuration of the analog inputs

Different types of thermocouples or a KTY sensor can be selected as temperature sensor of each temperature controller by making settings in the buffer memory addresses 330 to 339. The analog input can be set for measuring a voltage between 0 and 10 V as well.

When set as voltage input, the temperature curve is presumed to be linear. If e.g. a temperature between 0 and 250 °C gives a voltage reading from 0 to 10 Volts, the temperature for a setpoint of 5 V will be 125 °C.

Type of input		Input range	Digital value	Temperature range
Thermocouple	Type J	-30 mV to +30 mV	0 to 5000	0 to 500.0 °C
	Type K			
	Type L			
	Type U			
KTY sensor			0 to 5000	0 to 500.0 °C
Voltage input		0 to 10 V DC	0 to 10000	—

Tab. 2-3: Selectable types of inputs

The following buffer memory areas are connected to the analog inputs of the RE10TC:

Buffer Memory Address (decimal)	Name	Description	Real value/ Set value
0 to 9	Measured values	Scaled values from the analog inputs	Real values
27	Status flags of the RE10TC	Indication of activated calibration	Real values
45	Measured value is outside the input range	Indication of an measured value which is outside the input range	Real values
260 to 269	Temperature offset	Correction value for the measured temperature	Set values
330 to 339	Operation mode	Selection of the type of input and the type of thermocouple	Set values

Tab. 2-4: Buffer memory areas for analog inputs

2.2.2 Monitoring of the temperature sensors

The connected temperature sensors are constantly monitored for broken wire or short circuit.

To prevent cooling down of a heating zone when an fault occurs, an separat ON time for the corresponding output can be set.

The buffer memory allocation for the monitoring of the temperature sensors is shown on the next page:

Buffer Memory Address (decimal)	Name	Description	Real value/ Set value
26	Flags: sensor fault	Indication of a faulted temperature sensor	Real values
270 to 279	Duty cycle when sensor fault is detected	Setting of a fixed duty cycle for the outputs in case of sensor fault	Set values
280 to 289	Delay for sensor monitoring	On delay for sensor monitoring	Set values

Tab. 2-5: Buffer memory areas for monitoring of the temperature sensors

2.2.3 Alarms

Four alarms (two upper and two lower limits) can be set for each controller. Each limit can be activated or deactivated by the PLC. When the monitoring is switched on, flags in the buffer memory are used to show if a certain limit or warning has been reached.

The values are entered as relative values. The limit is worked out from the set value of the respective heating zone \pm the relative values. With this type of setting, the tolerance range remains constant even when the set values are changed.

In the following figure, the upper warning value is set to be 10 K above the set value. If the actual value is 15 K higher than the setpoint, the upper limit is reached. The alarm from the lower warning value should be go on when the actual value is 5 K below the setpoint. When the actual value is 15 K smaller than the setpoint, the alarm for the lower limit is rised.



Abb. 2-2: Limits and warnings

The reporting of the lower warning value or limit after switching on is suppressed until the lower values are crossed once. During this period, only the upper warning value and limit alarm are active.

This feature is activated after the power supply to the RE10TC has been switched on (buffer

memory address #325 = 0). If buffer memory address #325 is set to a value of "1", then the lower limits are immediately activated (see 3.3.13).

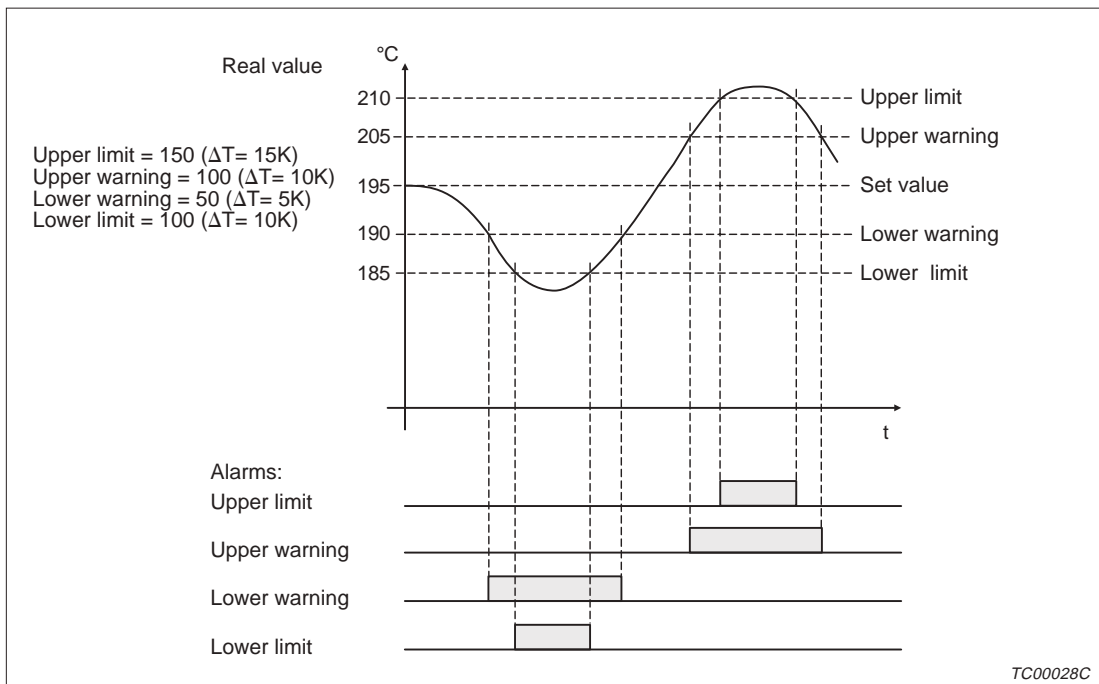
Buffer Memory Address (decimal)	Name	Description	Real value/ Set value
22 to 25	Alarm flags	Indication, whether a warning value or limit is reached	Real value
27	Status flags of the RE10TC	Bit 1 is set when the lower alarms are active	Real value
140 to 149	Lower limits	Set values for the lower limits	Set values
150 to 159	Upper limits	Set values for the upper limits	Set values
160 to 169	Lower warnings	Set values for the lower warnings	Set values
170 to 179	Upper warnings	Set values for the upper warnings	Set values
325	Monitoring of the lower limits and lower warnings	Selection, whether the lower warnings and lower alarms must be exceeded once or not to activate these alarms	Set value
342 to 345	Alarms ON/OFF	The monitoring of every alarm can be switched ON or OFF	Set values

Tab. 2-6: Buffer memory areas for alarms

2.3 Measurement of the heating current

2.3.1 Measurement method

Only one current transformer is required for the ten heating circuits since only one heater is switched on during the measurement at a time. The heating currents of all heating circuits are measured in a sequent order.

The output of the current transformer is connected to the analog input of the RE10TC for heating current detection (see page 4-8). This input is designed to accept input signals in the range from 0 to 10 V with a resolution of 0.001 V.

2.3.2 Monitoring of the heating current

For each heating circuit a minimum heating current must be set which should flow when the heating is switched on. If the actual heating current is less than the minimum heating current, e.g. because of a broken wire or a fault in the heating element, an alarm flag is set in the BFM #46.

Since the RE10TC does not monitor the heating currents in a fixed cycle, the monitoring of the heating current must be controlled by the PLC

Three bits in the control word which range from the PLC towards the RE10TC are reserved to control the monitoring of the heating current:

- Activate heating current monitoring (buffer memory address #340, bit 4):
The outputs for which heating current monitoring has been defined (entered in buffer memory address #347) are no longer controlled by the temperature controllers. This is required if there are connections from several heating zones, controlled by different RE10TC modules via one current detector. In this case the RE10TC modules for which no heating current is initially to be measured must first be given the job "Activate monitoring of heating current" (buffer memory address #340, bit 4). Doing this means that their outputs will not be triggered and so will not corrupt subsequent heating current measurements. The RE10TC which is to measure the heating current then receives the instruction "Start monitoring heating current" (buffer memory address #340, bit 6)". With this temperature control module, if heating current monitoring is shut down (buffer memory address #27, bit 11), then the instruction "End heating current monitoring (buffer memory address #340, bit 5)" must still be given to the RE10TC module which previously received the instruction "Activate monitoring of heating current" (buffer memory address #340, bit 4). Outputs will be triggered again by doing this.
- End heating current monitoring (buffer memory address #340, bit 5):
Setting bit 5 in the RE10TC's control word cancels the status that was created by setting bit 4 ("Activate heating current monitoring"). Outputs will then be controlled again by the temperature controllers.
- Start heating current monitoring (buffer memory address #340, bit 6):
The monitoring cycle in which the currents in the individual heaters are captured, begins. After one measurement cycle, heating current monitoring will stop automatically. The instruction "End heating current monitoring (buffer memory address #340, bit 5)" must not be used to end heating current monitoring.

2.3.3 Monitoring of the leakage current

The maximum leakage current (buffer memory address #304) is the maximum current that may flow, when all heaters are switched off. If this value is exceeded, for example if a heater cannot be switched off due to a defective solid state relay, an alarm bit will be set. In addition, the value that was measured will be stored in buffer memory address #42.

Leakage current is recorded after heating current monitoring has started (see above), but before the heating currents have been measured. If the leakage current measured is over the maximum (buffer memory address #304), then heating current monitoring will be stopped.

The relevant areas for the monitoring of the heating current and the leakage current in the buffer memory are shown in the following table:

Buffer Memory Address (decimal)	Name	Description	Real value/ Set value
27	Status flags of the RE10TC	State of the current monitoring	Real values
32 to 41	Measured heating currents	Measured heating currents	Real values
42	Measured leakage current	Measured leakage current	Real value
46	Error flags: Heating current	Flags for the indication of heating currents which are too low and a flag for excessive leakage current	Real value
294 to 303	Minimum heating currents	Settings for the min. heating currents	Set values
304	Maximal leakage current	Setting of the leakage current	Set value
326	Delay for measurement of the heating currents	Period from the start of the monitoring to the measurement of the current	Set value
340	Control flags from the PLC CPU	Controlling of the monitoring of the heating current	Set value
347	Monitoring of the heating current ON/OFF	Selection of the control circuits for which monitoring of the heating current should be performed	Set value

Tab. 2-7: Buffer memory areas for the monitoring of the heating and the leakage current monitoring of the heating current

3 Buffer Memory

NOTE

All data stored in the buffer memory is lost when the power supply of the RE10TC is switched off.

After turning on the power supply all setpoints and settings must be written to the buffer memory. It is strongly recommended to save the calculated PID constants after a self optimisation in the PLC.

3.1 Buffer memory list

3.1.1 Actual values

BFM# (decimal)	Meaning	Set range	Unit	Description	
0	Measured value	0 to 6000 0 to 10000	0.1 °C 0.001 V	Scaled measured value of the analog input The range and the unit are depending of the selected input type. See also Chapter 3.2.1	
1					Analog input 1
2					Analog input 2
3					Analog input 3
4					Analog input 4
5					Analog input 5
6					Analog input 6
7					Analog input 7
8					Analog input 8
9					Analog input 9
10	Control output value	-1000 to +1000	0.1%	The indication of the control output value is depending of the type of controller. For a two-position controller: 0.0 % to +100.0 % For a three-position controller: -100.0 % to +100.0 % See also Chapter 3.2.2	
11					Controller 1
12					Controller 2
13					Controller 3
14					Controller 4
15					Controller 5
16					Controller 6
17					Controller 7
18					Controller 8
19					Controller 9
20	State of the digital outputs for heating	—	—	Chapter 3.2.3	
21	State of the digital outputs for cooling	—	—	Chapter 3.2.3	
22	Alarms for lower limits	—	—	Chapter 3.2.4	
23	Alarms for upper limits				
24	Lower warnings				
25	Upper warnings	—	—	Chapter 3.2.4	
26	Flags: Sensor fault	—	—	Chapter 3.2.5	
27	Status flags of the RE10TC	—	—	Chapter 3.2.6	
28	Reserved for internal use	—	—		
29	Error flags of the RE10TC	—	—	Chapter 3.2.7	

Tab. 3-1: Buffer memory areas for actual values (1)

BFM# (decimal)	Meaning	Set range	Unit	Description	
30	Unit type code	9744	—	Unit type code of the RE10TC	
31	Reserved for internal use	—	—		
32	Heating current	0 to 10000	0.001 V	The measured value of the heating current is stored in this area when the measuring for the corresponding heating zone is enabled.	
					Heating zone 1
33					Heating zone 2
34					Heating zone 3
35					Heating zone 4
36					Heating zone 5
37					Heating zone 6
38					Heating zone 7
39					Heating zone 8
40					Heating zone 9
41	Heating zone 10				
42	Leaking current	0 to 10000	0.001 V	Measured value of the heating current when all the heating zones are switched off	
43	Reference temperature	0 to 6000	0.1 °C	Cold contact temperature measured with KTY-sensor	
44	Offset voltage	−4096 to 4096	Counts	Internal reference (0 V)	
45	Limit or warning value reached	—	—	Chapter 3.2.8	
46	Error flags: Heating current	—	—	Chapter 3.2.9	
47	Status flags of the RE10TC	—	—	Reserved for future expansions (not used)	
48	Firmware version	—	—	During start-up of the RE10TC the version of the firmware is copied to this area.	
49	Reserved for internal use				
50	State of the self optimisation			Chapter 3.2.10	
					Controller 1
51					Controller 2
52					Controller 3
53					Controller 4
54					Controller 5
55					Controller 6
56					Controller 7
57					Controller 8
58					Controller 9
59	Controller 10				

Tab. 3-2: Buffer memory areas for actual values (2)

BFM# (decimal)	Meaning		Set range	Unit	Description
60	Proportional band (X _P) for heating (calculated value during self optimisation)	Controller 1		0.1	After self optimisation of the controller the calcu- lated value for X _P is en- tered in this area.
61		Controller 2			
62		Controller 3			
63		Controller 4			
64		Controller 5			
65		Controller 6			
66		Controller 7			
67		Controller 8			
68		Controller 9			
69		Controller 10			
70	Proportional band (X _P) for cooling (calculated value during self optimisation)	Controller 1		0.1	After self optimisation of the controller the calcu- lated value for X _P is en- tered in this area.
71		Controller 2			
72		Controller 3			
73		Controller 4			
74		Controller 5			
75		Controller 6			
76		Controller 7			
77		Controller 8			
78		Controller 9			
79		Controller 10			
80	Integral time (T _I) (calculated value during self optimisation)	Controller 1		100 ms	After self optimisation of the controller the calcu- lated value for the integ- ral time T _I (I-constant) is entered in this area.
81		Controller 2			
82		Controller 3			
83		Controller 4			
84		Controller 5			
85		Controller 6			
86		Controller 7			
87		Controller 8			
88		Controller 9			
89		Controller 10			
90	Derivative time (T _D) (calculated value during self optimisation)	Controller 1		100 ms	After self optimisation of the controller the calcu- lated value for the deriv- ative time T _D (D-con- stant) is entered in this area.
91		Controller 2			
92		Controller 3			
93		Controller 4			
94		Controller 5			
95		Controller 6			
96		Controller 7			
97		Controller 8			
98		Controller 9			
99		Controller 10			

Tab. 3-3: Buffer memory areas for actual values (3)

BFM# (decimal)	Meaning	Set range	Unit	Description	
100	Self optimisation step			While the self optimisation is in progress step numbers are entered in this area of the buffer memory.	
101					Controller 1
102					Controller 2
103					Controller 3
104					Controller 4
105					Controller 5
106					Controller 6
107					Controller 7
108					Controller 8
109					Controller 9

Tab. 3-4: Buffer memory areas for actual values (4)

3.1.2 Set values

BFM# (decimal)	Meaning		Set range	Unit	Default value	Description
120	Set values for temperature	Controller 1	0 to 6000	0.1 °C	200	Chapter 3.3.1
121		Controller 2				
122		Controller 3				
123		Controller 4				
124		Controller 5				
125		Controller 6				
126		Controller 7				
127		Controller 8				
128		Controller 9				
129		Controller 10				
130	Set values for temperature (stand-by mode)	Controller 1	0 to 6000	0.1 °C	200	Chapter 3.3.2
131		Controller 2				
132		Controller 3				
133		Controller 4				
134		Controller 5				
135		Controller 6				
136		Controller 7				
137		Controller 8				
138		Controller 9				
139		Controller 10				
140	Lower limits (LL)	Controller 1	0 to 1000	0.1 K	0	Chapter 3.3.3
141		Controller 2				
142		Controller 3				
143		Controller 4				
144		Controller 5				
145		Controller 6				
146		Controller 7				
147		Controller 8				
148		Controller 9				
149		Controller 10				
150	Upper limits (UL)	Controller 1	0 to 1000	0.1 K	0	Chapter 3.3.3
151		Controller 2				
152		Controller 3				
153		Controller 4				
154		Controller 5				
155		Controller 6				
156		Controller 7				
157		Controller 8				
158		Controller 9				
159		Controller 10				

Tab. 3-5: Buffer memory areas for set values (1)

NOTE

| The entered set values for the limits are not checked against the range by the RE10TC.

BFM# (decimal)	Meaning		Set range	Unit	Default value	Description
160	Lower warning value (LW)	Controller 1	0 to 1000	0.1 K	0	Chapter 3.3.3
161		Controller 2				
162		Controller 3				
163		Controller 4				
164		Controller 5				
165		Controller 6				
166		Controller 7				
167		Controller 8				
168		Controller 9				
169		Controller 10				
170	Upper warning value (UW)	Controller 1	0 to 1000	0.1 K	0	Chapter 3.3.3
171		Controller 2				
172		Controller 3				
173		Controller 4				
174		Controller 5				
175		Controller 6				
176		Controller 7				
177		Controller 8				
178		Controller 9				
179		Controller 10				
180	Proportional band X _P (heating)	Controller 1	0 to 500	0.1	50	Set values for the proportional band of the PID-controllers
181		Controller 2				
182		Controller 3				
183		Controller 4				
184		Controller 5				
185		Controller 6				
186		Controller 7				
187		Controller 8				
188		Controller 9				
189		Controller 10				
190	Proportional band X _P (cooling)	Controller 1	0 to 500	0.1	50	Set values for the proportional band of the PID-controllers
191		Controller 2				
192		Controller 3				
193		Controller 4				
194		Controller 5				
195		Controller 6				
196		Controller 7				
197		Controller 8				
198		Controller 9				
199		Controller 10				

Tab. 3-6: Buffer memory areas for set values (2)

BFM# (decimal)	Meaning		Set range	Unit	Default value	Description
200	Integral time (Ti)	Controller 1	0 to 60000	100 ms	500	Chapter 3.3.4
201		Controller 2				
202		Controller 3				
203		Controller 4				
204		Controller 5				
205		Controller 6				
206		Controller 7				
207		Controller 8				
208		Controller 9				
209		Controller 10				
210	Derivative time (Td)	Controller 1	0 to 60000	100 ms	80	Chapter 3.3.5
211		Controller 2				
212		Controller 3				
213		Controller 4				
214		Controller 5				
215		Controller 6				
216		Controller 7				
217		Controller 8				
218		Controller 9				
219		Controller 10				
220	Shortest ON time (heating)	Controller 1	0 to 100	10 ms	5	Chapter 3.3.6
221		Controller 2				
222		Controller 3				
223		Controller 4				
224		Controller 5				
225		Controller 6				
226		Controller 7				
227		Controller 8				
228		Controller 9				
229		Controller 10				
230	Shortest ON time (cooling)	Controller 1	0 to 100	10 ms	5	Chapter 3.3.6
231		Controller 2				
232		Controller 3				
233		Controller 4				
234		Controller 5				
235		Controller 6				
236		Controller 7				
237		Controller 8				
238		Controller 9				
239		Controller 10				

Tab. 3-7: Buffer memory areas for set values (3)

BFM# (decimal)	Meaning		Set range	Unit	Default value	Description
240	Correction constant for cooling	Controller 1			0	Not used
241		Controller 2				
242		Controller 3				
243		Controller 4				
244		Controller 5				
245		Controller 6				
246		Controller 7				
247		Controller 8				
248		Controller 9				
249		Controller 10				
250	Correction constant for the measured value of the temperature	Controller 1			0	Not used
251		Controller 2				
252		Controller 3				
253		Controller 4				
254		Controller 5				
255		Controller 6				
256		Controller 7				
257		Controller 8				
258		Controller 9				
259		Controller 10				
260	Temperature offset	Controller 1	-500 to +500	0.1 K	0	Chapter 3.3.7
261		Controller 2				
262		Controller 3				
263		Controller 4				
264		Controller 5				
265		Controller 6				
266		Controller 7				
267		Controller 8				
268		Controller 9				
269		Controller 10				
270	Duty cycle when a sensor error is detected	Controller 1	-1000 to +1000	0.1 %	0	Chapter 3.3.8
271		Controller 2				
272		Controller 3				
273		Controller 4				
274		Controller 5				
275		Controller 6				
276		Controller 7				
277		Controller 8				
278		Controller 9				
279		Controller 10				

Tab. 3-8: Buffer memory areas for set values (4)

BFM# (decimal)	Meaning		Set range	Unit	Default value	Description
280	Delay for sensor monitoring	Controller 1	0 to 30	Minutes	0	Chapter 3.3.9
281		Controller 2				
282		Controller 3				
283		Controller 4				
284		Controller 5				
285		Controller 6				

BFM# (decimal)	Meaning	Set range	Unit	Default value	Description	
280	Delay for sensor monitoring	0 to 30	Minutes	0	Chapter 3.3.9	
281						Controller 1
282						Controller 2
283						Controller 3
284						Controller 4
285						Controller 5
286						Controller 6
287						Controller 7
288						Controller 8
289						Controller 9
290	Leading value: Proportional band	0 to 500	0.1	72	Chapter 3.3.10	
291	Leading value: Integral time	0 to 1000	100 ms	600		
292	Leading value: Derivative time	0 to 1000	100 ms	118		
293	Switching threshold for changing between lead value and regular PID constants	0 to 1000	0.1 K	70	Chapter 3.3.11	
294	Heating currents	0 to 10000	0.01 V	0	Setting of a min. heating current. If the measured value of the heating current is less than the min. current, an alarm is issued.	
295						Controller 1
296						Controller 2
297						Controller 3
298						Controller 4
299						Controller 5
300						Controller 6
301						Controller 7
302						Controller 8
303						Controller 9
304	Maximum leakage current	0 to 10000	0.01 V	0	The maximum leakage current is the current which may flow when all the heating zones are switched off	
305	Cooling constant	0 to 500	0.1	180	Chapter 3.3.128	
306						Controller 1
307						Controller 2
308						Controller 3
309						Controller 4
310						Controller 5
311						Controller 6
312						Controller 7
313						Controller 8
314						Controller 9

Tab. 3-9: Buffer memory areas for set values (5)

BFM# (decimal)	Meaning	Set range	Unit	Default value	Description	
315	Switching threshold for cooling constant	0 to 1500	0.1 K	1050	Chapter. 3.3.12	
316						Controller 1
317						Controller 2
318						Controller 3
319						Controller 4
320						Controller 5
321						Controller 6
322						Controller 7
323						Controller 8
324						Controller 9
325	Monitoring of the lower limits and lower warnings	—	—	0	Chapter 3.3.13	
326	Delay for measurement of the leaking current	100 to 2000	ms	300		
327	Control of the outputs for heating by the PLC	—	—	0	Chapter 3.3.14	
328	Control of the outputs for cooling by the PLC	—	—	0		

Tab. 3-10: Buffer memory areas for set values (6)

3.1.3 Control flags

BFM# (decimal)	Meaning	Default value	Description	
330	Operation mode	3	Chapter 3.3.15	
331				Controller 1
332				Controller 2
333				Controller 3
334				Controller 4
335				Controller 5
336				Controller 6
337				Controller 7
338				Controller 8
339				Controller 9
340	Control flags from the PLC CPU	0	Chapter 3.3.16	
341	Controller ON/OFF	0	Chapter 3.3.17	
342	Lower limit alarms ON/OFF	0	Chapter 3.3.18	
343	Upper limit alarms ON/OFF	0		
344	Lower warnings ON/OFF	0		
345	Upper warnings ON/OFF	0		
346	Reserved for internal use	0		
347	Monitoring of the heating current ON/OFF	0	Chapter 3.3.19	
348	Watchdog	1	Chapter 3.3.20	

Tab. 3-11: Buffer memory areas for control flags

3.2 Details of the real values

3.2.1 Actual temperatures (BFM #0 to BFM #9)

In this area of the buffer memory, the values measured by the ten controllers are entered. If a thermocoupler input has been configured for a controller ("Operation mode", buffer memory addresses #330 to #339), then the value measured will be directly given as a temperature with a resolution of 0.1°C. For voltage input configurations ranging from 0 to 10V, the voltage measured is recorded with a resolution of 1 mV.

Thermo-coupler configured inputs are given with a measured value of "-1", if the measurement input is open. If no signal is connected to an input configured as a voltage input, then a value greater than 10,000 will be given.

If neither a thermo-coupler input, nor a KTY input, nor a voltage input is configured, then "-1" will be given.

3.2.2 Duty cycle (BFM #10 to BFM #19)

The duty cycle of the controller's switch outputs is entered in the buffer storage between buffer memory addresses #10 and #19. A positive value indicates that the controller's heating output is switched on. The cooling output is switched on if the value is negative.

The duty cycle gives the pulse width ratio between the "switched on" and "not switched on" states. A value of 1000 corresponds to a duty cycle of 100%, i.e. the output is continuously on. A duty cycle of 50% means that the output is on for 50% of the time and off for 50% of the time.

The time period used for the pulse width ratio can be adjusted using the setting "Heating switch period duration" (buffer memory address #220 to buffer memory address #229) and the "Cooling switch period duration" (buffer memory address #230 to buffer memory address #239).

3.2.3 State of the digital outputs (BFM #20 and BFM #21)

These two data words are used to indicate the states of the outputs of the RE10TC:

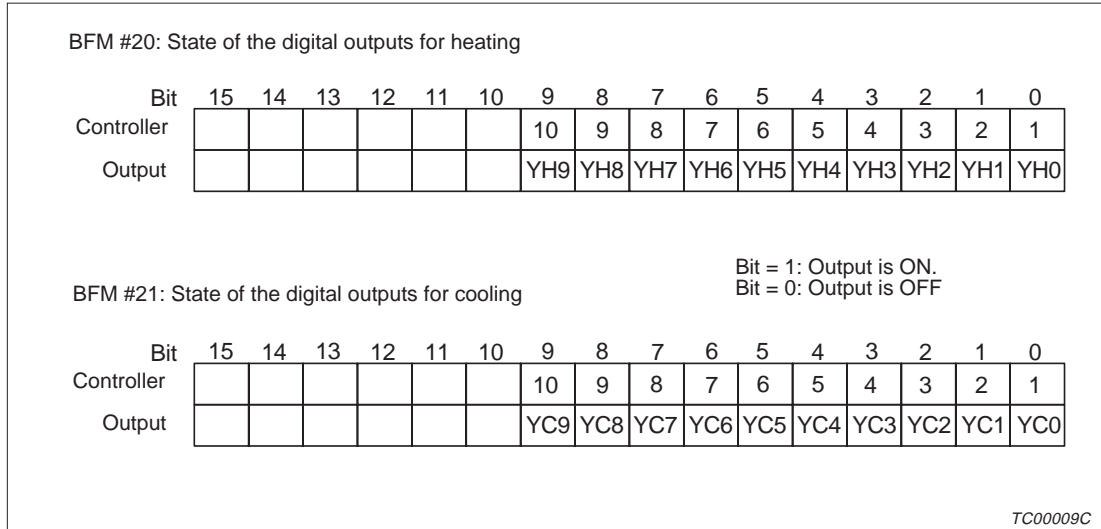

Fig. 3-2: Configuration of the buffer memory addresses 20 and 21

3.2.4 State of the alarms and warnings (BFM #22 to BFM #25)

The flags in these four data words indicate which of the analog inputs have reached a limit or warning value. A flag is ON as long as the real value has exceeded the limit or warning value. The flag is reset when the real value of the input is back inside the border of the limit. If the real value for example becomes smaller than the upper limit, the respective flag turns OFF.

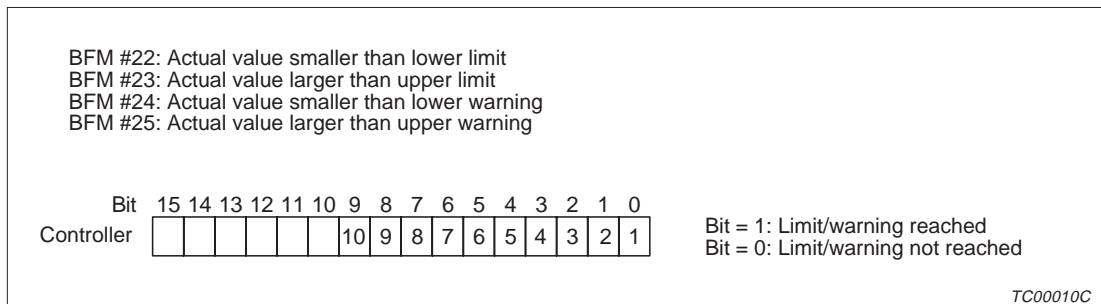

Fig. 3-1: Configuration of the buffer memory addresses 22 to 25

3.2.5 Flags: Sensor fault (BFM #26)

One flag for each temperature controller is used to indicate a sensor fault.

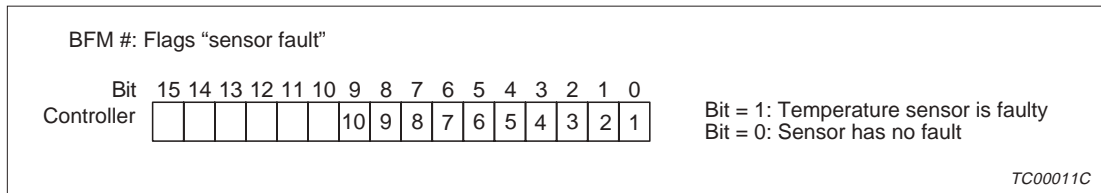

Fig. 3-3: Contents of buffer memory address 26

3.2.6 Status flags of the RE10TC (BFM #27)

The BFM #27 contains several flags which indicate the status of the temperature control modul.

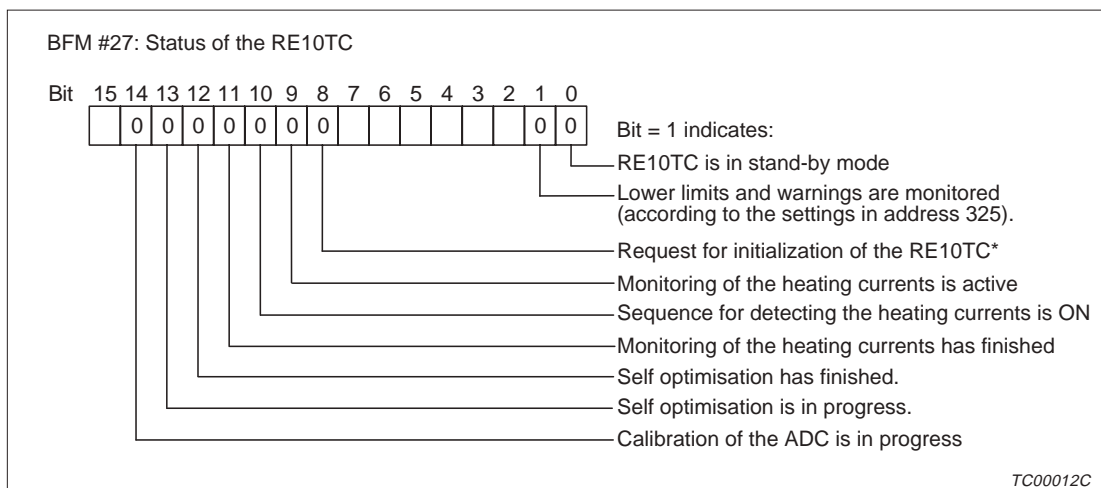

Fig. 3-4: Status flags of the RE10TC in buffer memory address 27

* The request for initialization is set by the RE10TC immediately after module start-up. The only way to reset this flag is by turning bit 12 of the BFM #340 ON (refer to 3.3.16). After copying the settings from the PLC to the RE10TC the request for initialization must be reset in order to recognize a reset of the RE10TC.

3.2.7 Error flags of the RE10TC (BFM #29)

The contents of this buffer memory address are used exclusively for production engineering purposes.

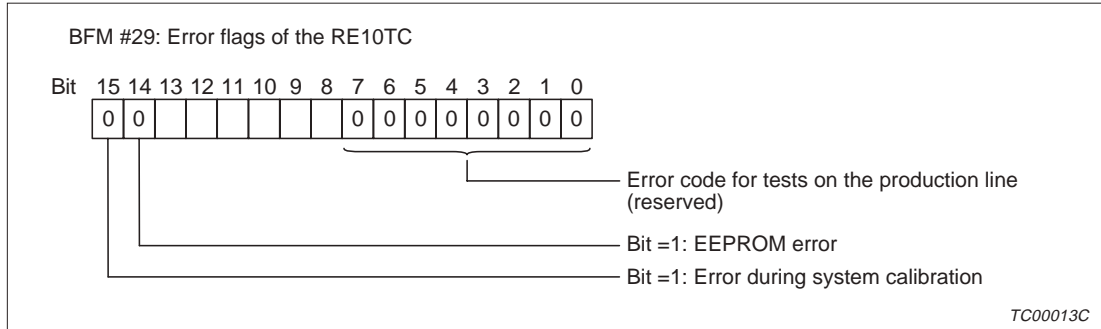

Fig. 3-6: Contents of buffer memory address 29

3.2.8 Measured value is outside the input range (BFM #45)

In buffer memory address #45, the bit for the corresponding controller is set if a warning or limit value is damaged.

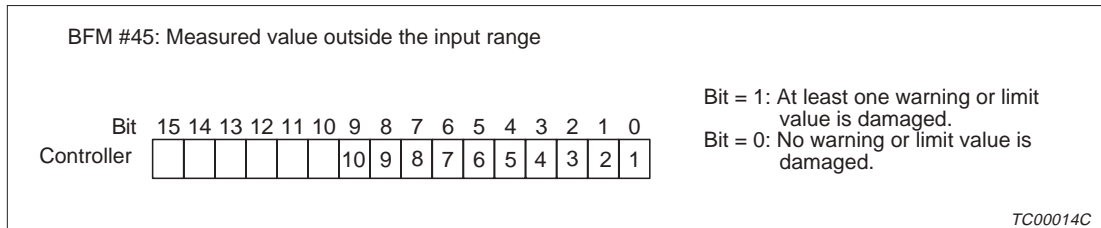

Fig. 3-5: Contents of buffer memory address 45

3.2.9 Error flags: Heating current (BFM #46)

An error flag is set when the measured heating current of a heating zone is less than the set minimum heating current.

Bit 14 indicates that the measured leakage current is higher than the set value. The leakage current is detected before the heating currents are measured. In case of a too high leakage current, the sequence for monitoring the heating currents is ended immediately.

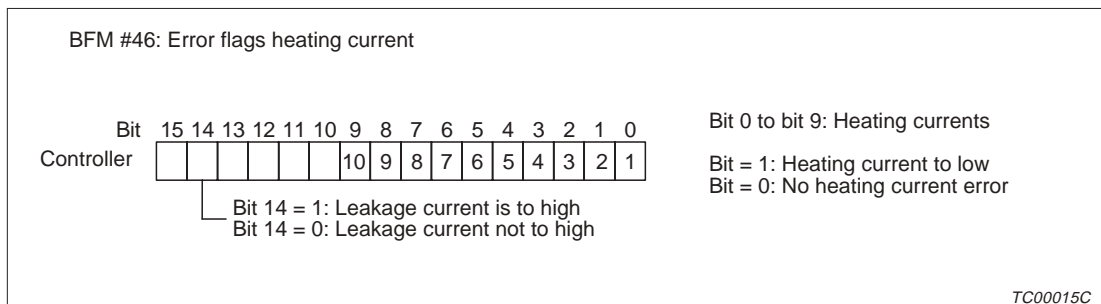

Fig. 3-7: Allocation of flags in buffer memory address 46

3.2.10 State of the self optimisation (BFM #50 to BFM #59)

One data word is reserved for each temperature controller. During self optimisation relevant informations about the progress of the optimisation are indicated by flags.

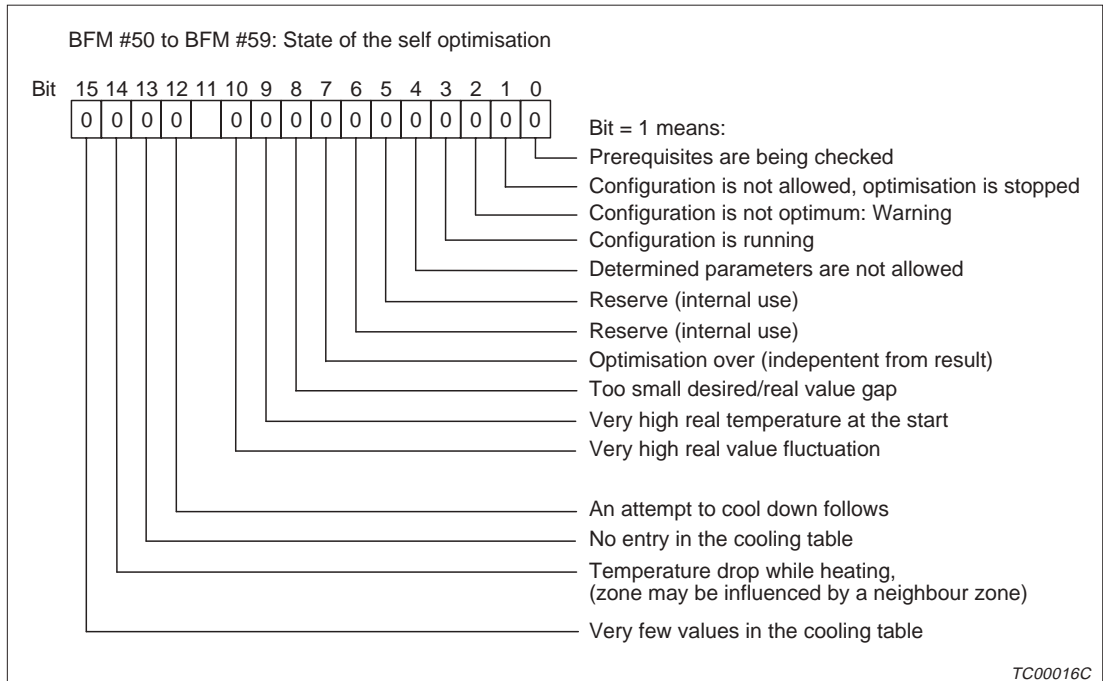

Fig. 3-8: Contents of buffer memory addresses 50 to 59

TCE0018C

3.3 Details of the set values

NOTE

| The entered set values are not checked against the range by the RE10TC.

3.3.1 Set values for temperatures (BFM #120 to BFM #129)

The desired values of the temperatures are entered in this area of the buffer memory.

NOTE

| To validate changed set values, bit 1 of BFM #340 must be switched ON after changing of the set values (refer to 3.3.16).

3.3.2 Set values for temperatures in stand-by mode (BFM #130 to BFM #139)

The temperatures of the ten heating zones can be lowered simultaneously by activating the stand-by mode. The set values for the temperatures in stand-by mode are entered in the buffer memory area from BFM #130 to BFM #139. To enter the stand-by mode, bit 9 of BFM #340 has to be switched ON. The set values in the BFM #120 to BFM #129 become valid again when the stand-by mode is switched OFF by setting bit 1 of BFM #340 to ON.

NOTE

| To validate changed set values, bit 9 of the buffer memory address 340 must be switched ON after changing of the set values (refer to 3.3.16).

3.3.3 Limits and warnings (BFM #140 to BFM #179)

In this area, the maximum and minimum temperature warning values and set limits of the individual zones are entered. The values are entered as relative values. The limit is worked out from the set desired value of the respective heating zone \pm the relative values.

With this type of setting, the tolerance range remains constant even when the desired values are different.

In the following example, a upper limit value of 100 (10.0 K) and a lower limit value of 150 (15.0 K) is set.

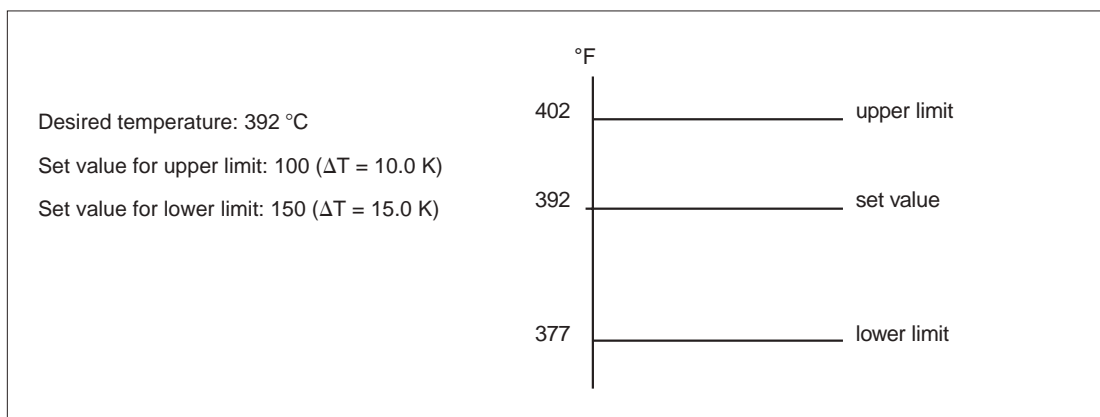

Fig. 3-9: Example for the setting of limits

3.3.4 Integral time T_I (BFM #200 to BFM #209)

One dataword in the buffer memory area is reserved for the integral time of each temperature controller.

The integral time can be entered in steps of 100 ms. If the integral time is set to zero, the I portion of the controller is switched off.

NOTE

To validate changed set values, bit 0 of the buffer memory address 340 must be switched ON after changing of the set values (refer to 3.3.16).

3.3.5 Derivative time T_D (BFM #210 to BFM #219)

The derivative time can be entered in steps of 100 ms. If the derivative is set to zero, the D portion of the controller is switched off.

NOTE

Only after setting bit 0 of BFM #340 to "1" changed set values become valid (refer to 3.3.16).

3.3.6 Shortest ON time for heating and cooling (BFM #220 to BFM #239)

The entered value is the ON time for an output at a duty cycle of 1%. The unit are 10 ms. A duty cycle less than 5 % is suppressed.

Calculation of the minimum ON time:

$$t = (\text{value for shortest ON time}) \times 10 \text{ ms} \times 5 (\%)$$

NOTE

To validate changed set values, bit 0 of the buffer memory address 340 must be switched ON after changing of the set values (refer to 3.3.16)..

3.3.7 Temperature offset (BFM #260 to BFM #269)

The offset value is added to the measured value of the temperature in order to decrease or increase the real value.

NOTE

To validate changed temperature offsets, bit 0 of the buffer memory address 340 must be switched ON after changing of the offsets (refer to 3.3.16).

3.3.8 Duty cycle when a sensor error is detected (BFM #270 to BFM #279)

The duty cycle stands for the on ratio of an output:

0 %: switched off

50 %: switched on for half the period

100 %: continuously switched on.

A fixed duty cycle can be specified for each controller. The respective output is driven with this duty cycle when a error is detected for the temperature sensor by the sensor short circuit monitoring.

3.3.9 Monitoring time for temperature sensor short circuit monitoring (BFM #280 to BFM #289)

Temperature sensor short circuit monitoring is switched on when a monitoring time value greater than 0 has been entered. If "0" is entered, then this function is not activated.

When temperature sensor short circuit monitoring is switched on, then a check is run to see whether, with a duty cycle of 100% within a specified monitoring time, a rise in temperature of 2 °C was recorded. If this rise in temperature is not recorded, then a bit is set in buffer memory address #26 (sensor error) and the controller output is controlled with the duty cycle which was set in "Set value for duty cycle for sensor error (BFM #270 to BFM #279).

A sensor error recorded by temperature sensor short circuit monitoring can be re-set by switching off the controller assigned to that sensor.

NOTE

Only after setting bit 0 of the buffer memory address 340 to "1" changed set values for the delay time become valid (see chapter 3.3.16).

3.3.10 Leading values (BFM #290 to BFM #292)

All temperature controllers work with the leading parameters until the actual temperature of a controller reaches the parameter trigger temperature (see explanations at buffer memory address #293). Above this temperature the controller works within its normal control parameters.

NOTE

To validate changed leading values, bit 0 of the buffer memory address 340 must be switched ON after changing of the leading values (refer to 3.3.16).

3.3.11 Switching threshold for changing the PID constants (BFM #293)

A value for the deviation is entered in this address. This set value serves as a switching threshold for switching from the lead values defined in BFM #290 to the PID constants in the buffer memory addresses 180 to 219.

NOTE

To validate a changed switching threshold, bit 0 of the buffer memory address 340 must be switched ON after changing of the switching threshold (refer to 3.3.16).

3.3.12 Cooling constant & switching threshold for cooling constant (BFM #305 to BFM #324)

Water or air can be used for cooling. The cooling constant indicates how much a water cooling system is more effective than an air cooling system. When cooling with air, a typical cooling constant value is 10. For cooling with water, a cooling constant of 180 is normal practice.

The value for the switching threshold is that real value of the temperature from which on the cooling constant is valid. A typical value for a cooling constant starting point is 0. For cooling with water, a value of 1050 (105.0 °C) is normal practice.

NOTE

To validate changed cooling constants and thresholds, bit 0 of the buffer memory address 340 must be switched ON after changing of the set values (refer to 3.3.16).

3.3.13 Monitoring of the lower limits and warnings (BFM #325)

Depending of the entered value in the buffer memory address 325 the monitoring of the lower limits and warnings is handled in two different ways:

Contents of BFM #325 = 0: The reporting of the lower warning values or limits after switching on is suppressed until the lower values of all active controllers are crossed once. During this period, only the upper warning values and limit alarms are active.

Contents of BFM #325 # 0: The reporting of the lower warning or limits is activated without crossing the lower values once.

3.3.14 Control of the digital outputs by the PLC (BFM #327 and BFM #328)

Setting bit 3 in buffer memory address 340 to “1” enables the PLC to control the digital outputs of the RE10TC for heating or cooling. The outputs are set/reset according to the bit pattern written in BFM #327 and BFM #328. However, the PID control has a higher priority than the control by the PLC. Therefore outputs of a active controller cannot be set and are masked.

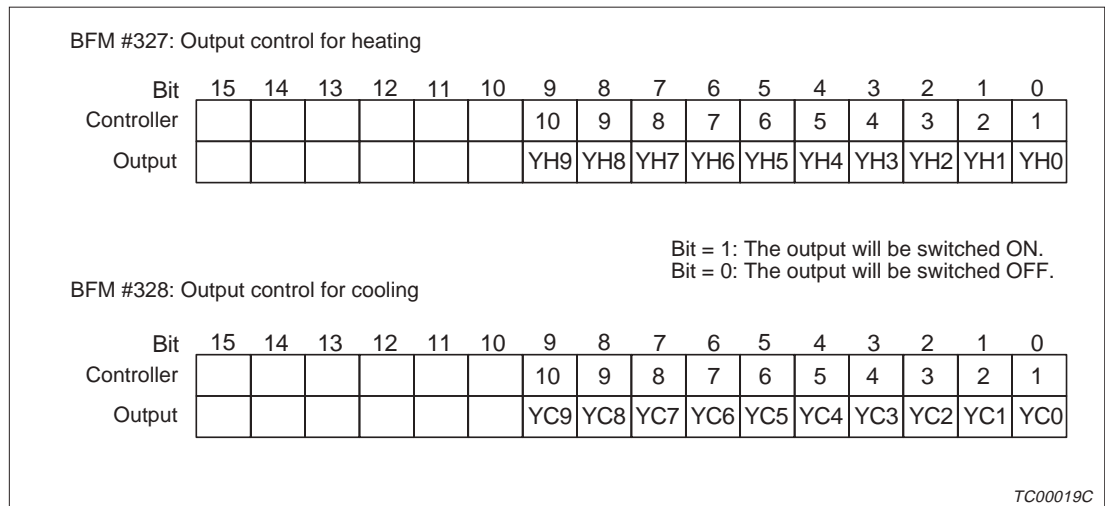

Fig. 3-10: Contents of the buffer memory addresses 327 and 328

3.3.15 Operation mode (BFM #330 to BFM #339)

These data words are used to select the type of controller, analog input and temperature sensor.

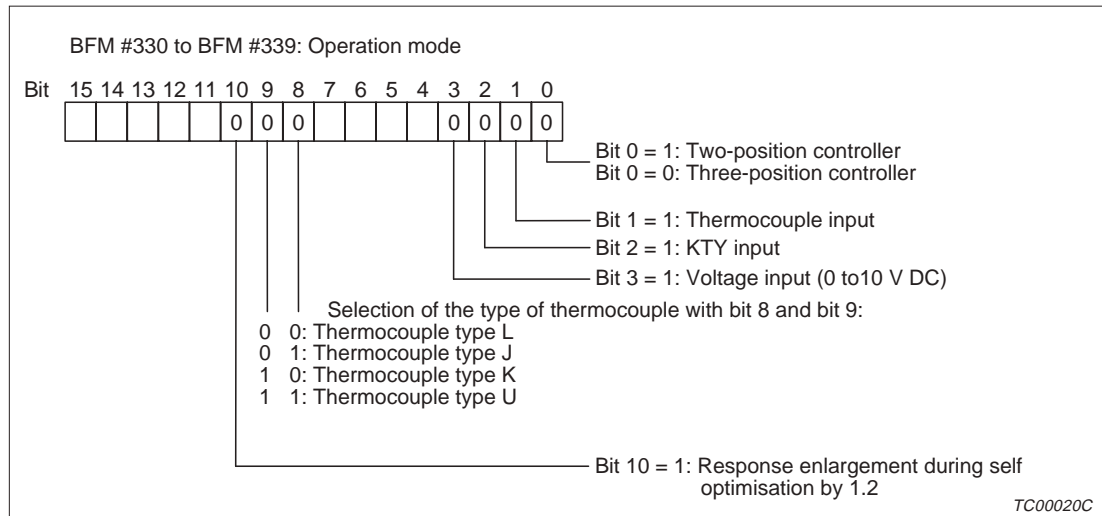

Fig. 3-11: Contents of the buffer memory addresses 330 to 339

A two-position controller is able to control the heating. A three-position controller can control heating and cooling.

By setting bit 10 to “1” the result of the self optimisation influenced. The response to disturbances becomes faster. The controlling however becomes less stable.

NOTE | To validate changes of the operation mode valid, bit 0 of the buffer memory address 340 must be switched ON after changing of the operation mode (refer to 3.3.16).

3.3.16 Control flags from the CPU of the PLC (BFM #340)

The bits of this data word are set and reset by the PLC CPU. By setting a flag the corresponding action for the temperature controller modul is selected. After the operation is over, the data word is reset to indicate the end of the execution.

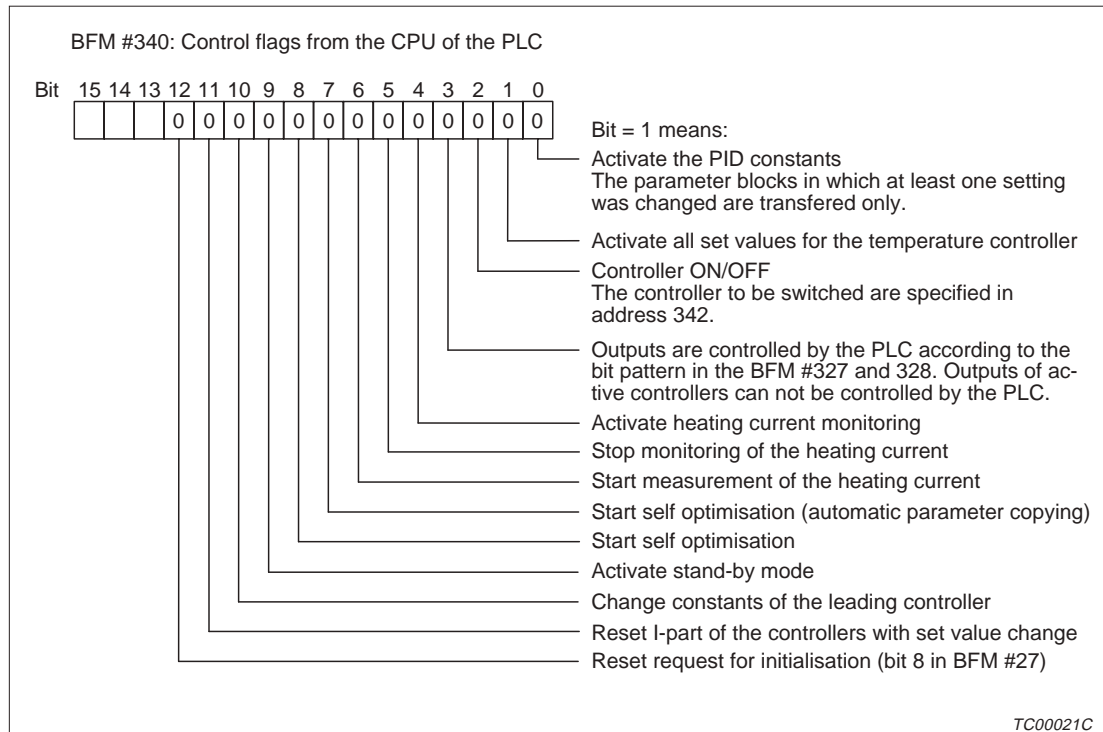

Fig. 3-13: Allocation of flags in buffer memory address 340

NOTE

More than one flag can be set at the same time. The sequence of execution begins with bit 0 and ends with bit 15.

3.3.17 Controller ON/OFF (BFM # 341)

By setting a bit of this data word the corresponding temperature controller is selected. The selected controllers are activated or deactivated simultaneously when bit 2 of the buffer memory 340 is set respectively reset.

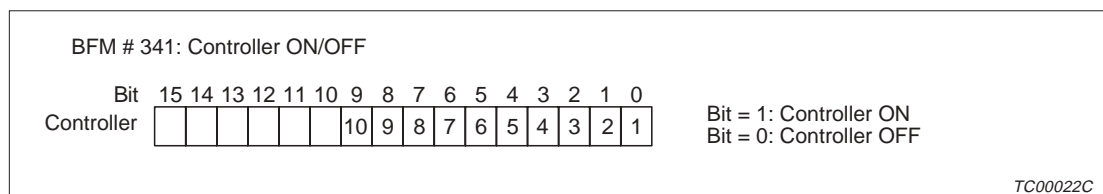

Fig. 3-12: Contents of buffer memory address 341

3.3.18 Monitoring of limits ON/OFF (BFM #342 to BFM #345)

The monitoring of each limit or warning value can be selected ON or OFF.

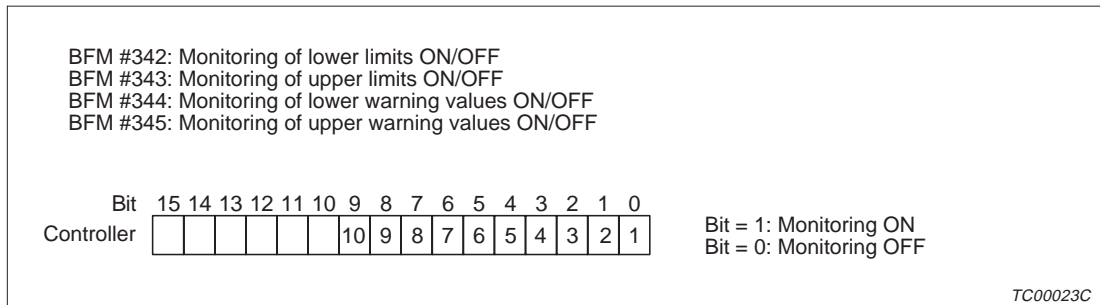

Fig. 3-16: Selection of limits and warnings

3.3.19 Monitoring of heating currents ON/OFF (BFM #347)

This address is used to select the controller for which the heating current is to be monitored.

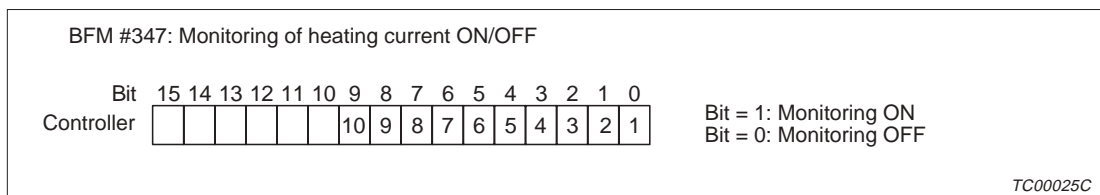

Fig. 3-14: Contents of buffer memory address 347

3.3.20 Watchdog (BFM #348)

Bit 0 in BFM #348 is set by the RE10TC. By resetting the bit in the sequence program of the PLC and checking that the bit has been switched ON again, the operation of the RE10TC can be confirmed.

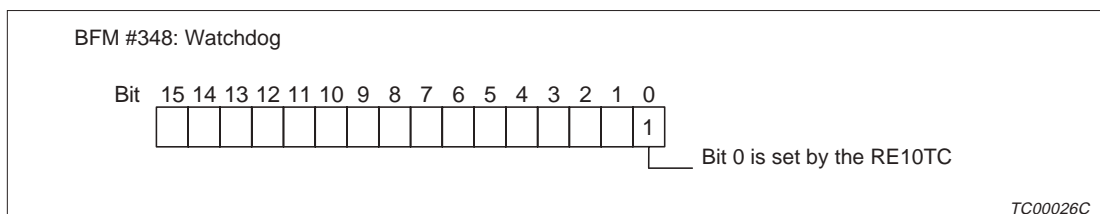

Fig. 3-15: Watchdog flag in buffer memory address 348

4 Installation

4.1 Name of each part

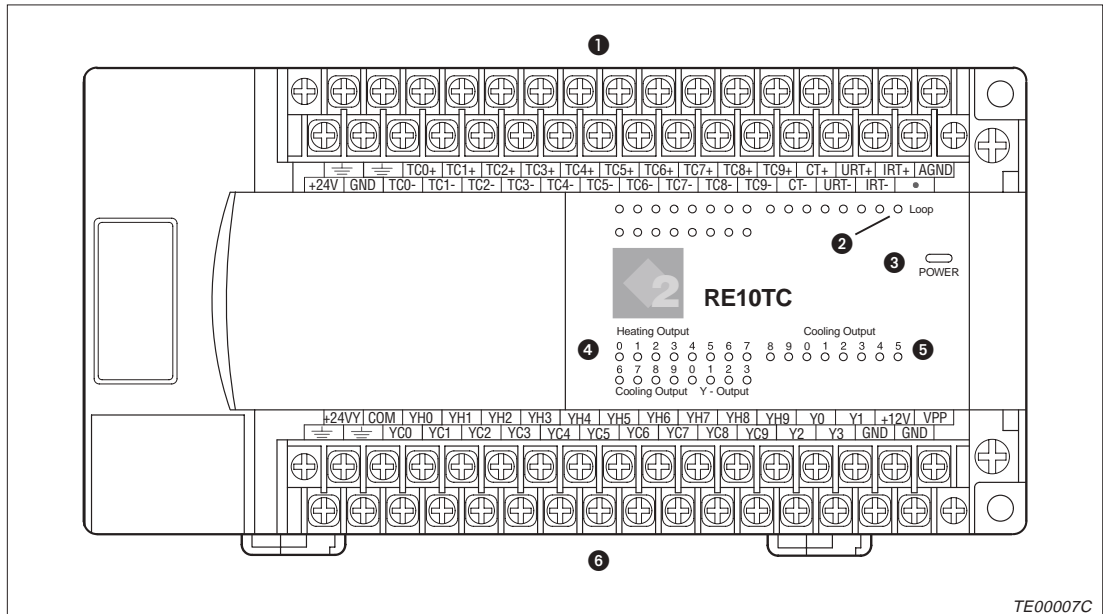

Fig. 4-1: Temperature control module RE10TC

- ① Connections for analog inputs (for description refer to 4.3)
- ② Loop-LED: Flickering indicates readiness of the module
- ③ Power-LED: Lit when the power supply of the outputs is on
- ④ LEDs for indicating a switched ON heating output
- ⑤ LEDs: Lit when the respective cooling output is ON
- ⑥ Connections for heating and cooling outputs (refer to 4.3)

4.2 Installation method

The temperature control module can be installed on the right side of a FX2N series PLC base unit or another module of the FX2N series.

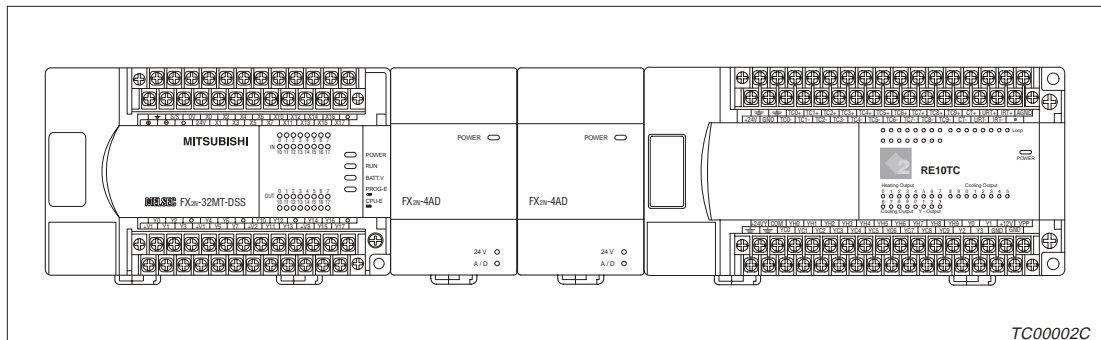

Fig. 4-2: Example installation of the RE10TC

- Connect the extension cable, which is protruding on the left side of the RE10TC, with the module on the left of the RE10TC.
- Align the upper side of the rail mounting groove of the module with the DIN rail, and push the RE10TC on the DIN rail.
- Make the necessary connections to the module.

When removing the RE10TC, pull out downward the DIN rail mounting hooks on the bottom side of the module with a screwdriver, then remove the module.

4.3 Wiring

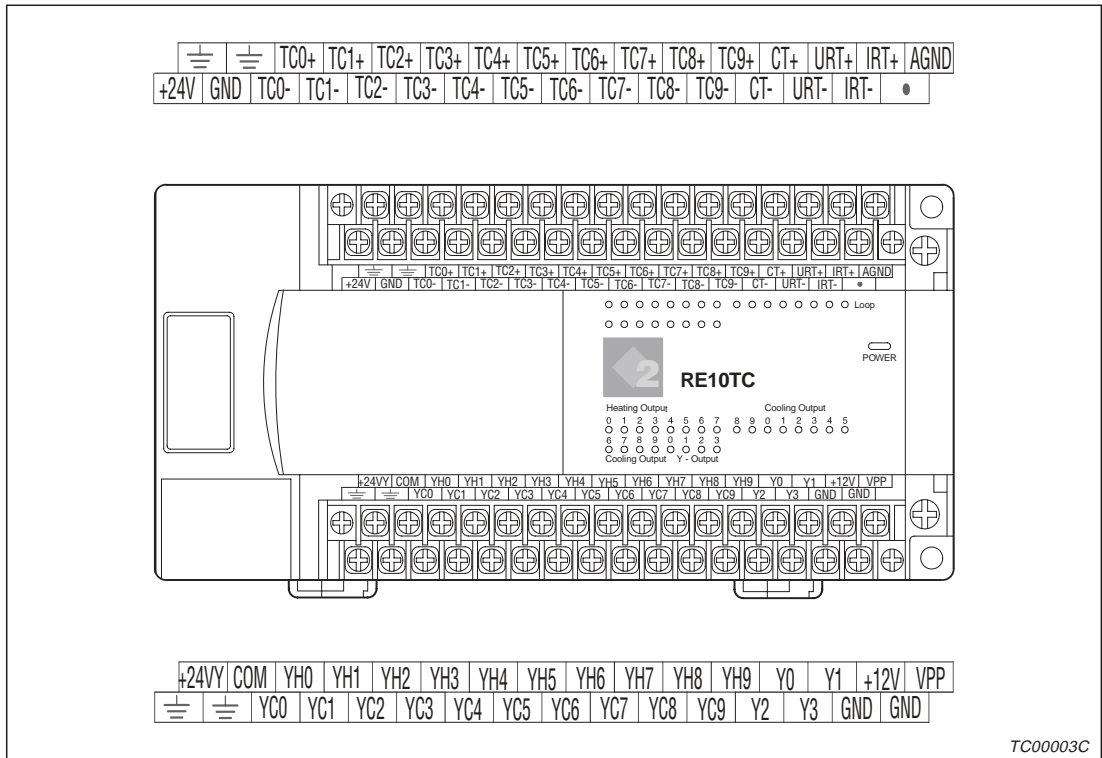

Fig. 4-3: Terminal blocks of the RE10TC

- Analogue inputs for thermocouples are designed for the -30 mV to +30 mV range. Input voltages in the range of -15 V to +15 V will do no harm to the module. However, this will cause crosstalk. To prevent this, the terminals of unused inputs should be short-circuited.
- The grounding terminal of the RE10TC should be connected with the grounding terminal of the PLC module.
- Pay attention to the notes concerning the connection of supply voltage, thermocouples, reference temperature input and digital outputs on the following pages.

Terminal	Meaning	Assignment
+24V	Power supply 24 V DC	Positive pole of 24 V DC voltage for supplying the module
GND		Negative pole of 24 V DC voltage for supplying the module
FE	Function earth	Module grounding
FE		
TC0+	Inputs for thermocouples (analog inputs)	Temperature zone 1
TC0-		
TC1+		Temperature zone 2
TC1-		
TC2+		Temperature zone 3
TC2-		
TC3+		Temperature zone 4
TC3-		
TC4+		Temperature zone 5
TC4-		
TC5+		Temperature zone 6
TC5-		
TC6+		Temperature zone 7
TC6-		
TC7+		Temperature zone 8
TC7-		
TC8+		Temperature zone 9
TC8-		
TC9+		Temperature zone 10
TC9-		
CT+	Input for heating current monitoring	Positive pole of the signal voltage (0 to 10 V)
CT-		Negative pole of the signal voltage (0 to 10 V)
URT+	Reference temperature input (KTY)	Voltage connections
URT-		
IRT+		Connections of constant current supply
IRT-		
AGND	Analog ground	
n. c.	Not configured	—

Tab. 4-1: Assignment of the upper terminal block of the FX2N-RE10TC

Terminal	Meaning	Assignment
+24VY	Power supply 24 V DC	Positive pole of 24 V DC voltage for supplying the outputs
COM		Negative pole of 24 V DC voltage for supplying the outputs
FE	Function earth	Module grounding
FE		
YH0	Output "heating"	Temperature zone 1
YC0	Output "cooling"	
YH1	Output "heating"	Temperature zone 2
YC1	Output "cooling"	
YH2	Output "heating"	Temperature zone 3
YC2	Output "cooling"	
YH3	Output "heating"	Temperature zone 4
YC3	Output "cooling"	
YH4	Output "heating"	Temperature zone 5
YC4	Output "cooling"	
YH5	Output "heating"	Temperature zone 6
YC5	Output "cooling"	
YH6	Output "heating"	Temperature zone 7
YC6	Output "cooling"	
YH7	Output "heating"	Temperature zone 8
YC7	Output "cooling"	
YH8	Output "heating"	Temperature zone 9
YC8	Output "cooling"	
YH9	Output "heating"	Temperature zone 10
YC9	Output "cooling"	
Y0	Not connected	—
Y1		
Y2		
Y3		
+12V	12 V DC voltage	Reserved for works after-sales service
GND(+12V)		
VPP	Programming voltage	Reserved for works after-sales service
GND (VPP)		

Tab. 4-2: Assignment of the upper terminal block of the FX2N-RE10TC

Connection of supply voltage and functional earthing

The module has two power supply inputs. The measurement and control part of the module is supplied power through terminals +24V and GND. Terminals +24VY and COM supply power to the outputs. We recommend a neutral wiring of both these supplies. The length of the supply lines should not exceed 10 m.

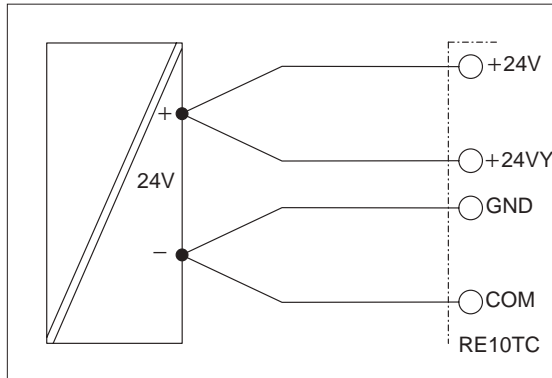

Fig. 4-4:
Neutral wiring

TC00004C

The LED "POWER" of the module lights only when the supply voltage is connected to the outputs.

The output supply voltage should also be secured with a fine safety device (6.3 A quick-acting fuse).

Connectors for functional earthing should be connected in direct proximity of the module with the mounting plate.

Connection of thermocouples

The thermocouple lines are to be laid on the mounting plate close to the module with shield terminals. The maximum line length is 30 m.

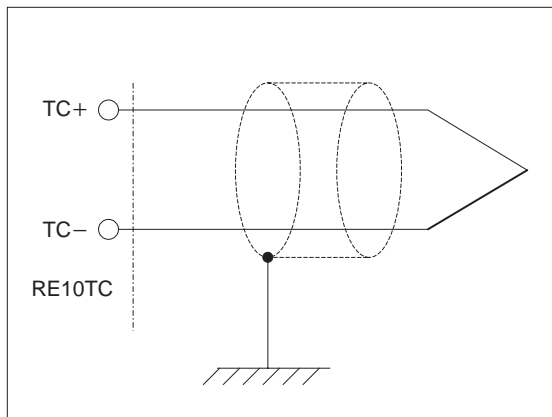

Fig. 4-5:
Connection of the thermocouples

TC00005C

NOTE

Temperature compensation takes place through an external KTY resistor on the clamping point (see KTY reference temperature input). The input connection is designed for isolated as well as for non-isolated thermocouples. Only isolated or only non-isolated thermo couples may be installed together. If non-isolated thermocouples are being used, then the thermocoupling point should be earthed.

KTY reference temperature input

Wiring in four-conductor technique and use of a shielded conductor are recommended for a line length from 0.5 m onwards. A 2-conductor wiring is sufficient for smaller line lengths. In this case, terminals IRT+ and URT+ as well as terminals IRT- and URT- are bridged on the connecting block of the module. The shielding of the KTY conductor should be laid on the mounting plate in the direct proximity of the module with shield terminals. The maximum line length is 30 m.

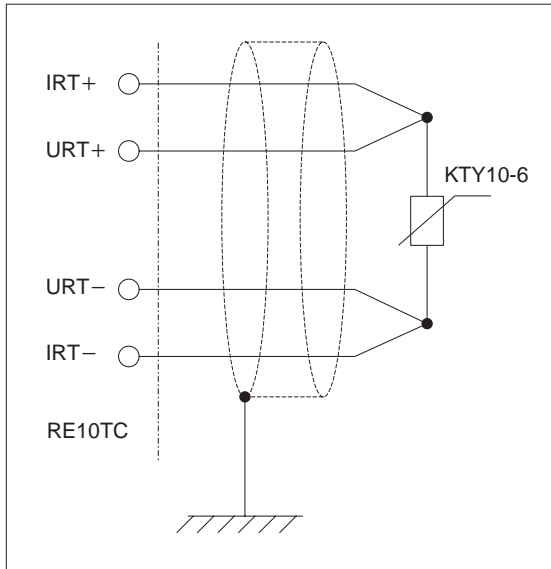

Fig. 4-6:
Connection of the KTY reference temperature sensor

TC00006C

Outputs for heating and cooling

Each output can be loaded with 500 mA. Line length should not exceed 30 m.

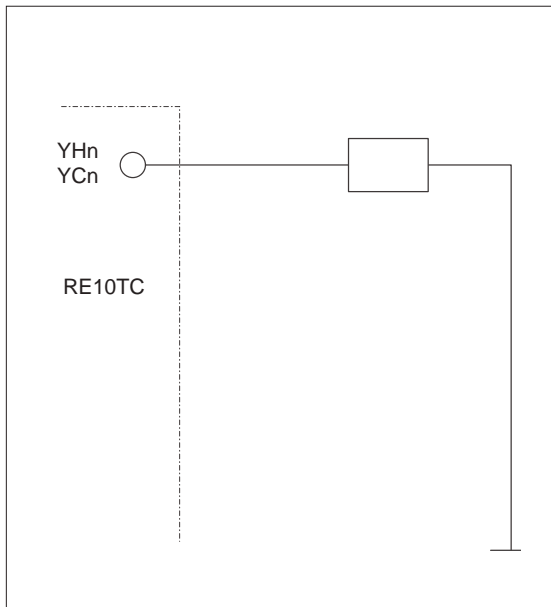

Fig. 4-7:
Circuitry of the outputs for heating and cooling

TC00007E

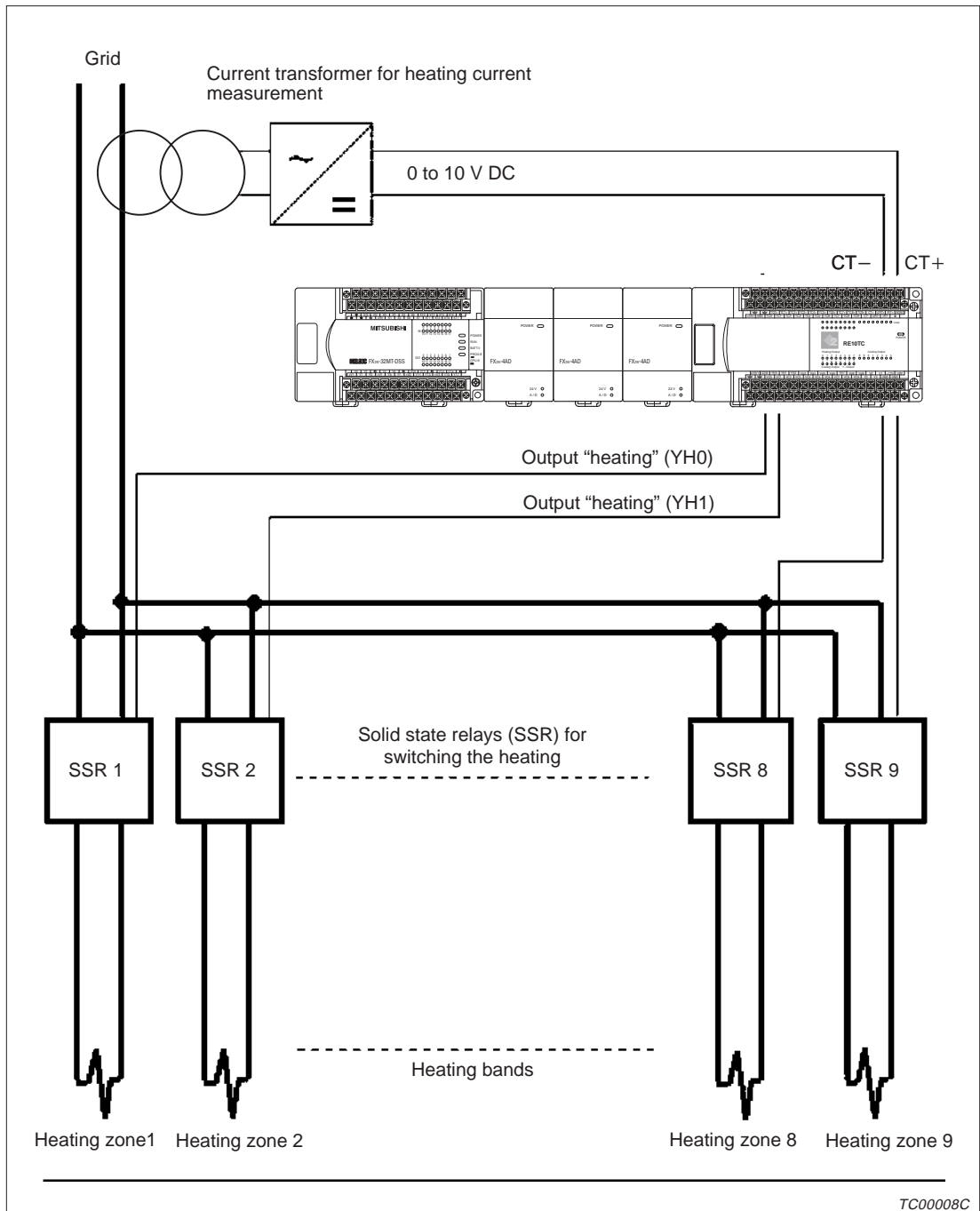

Fig. 4-8: Connection of the heating system and the current transformer for heating current measurement

NOTE

| The contactors for heating and cooling drives are to be shielded with RC-links.

5 Programming

NOTE

All settings in the buffer memory of the RE10TC are lost when the power supply of the temperature controller is switched off.

The contents of the buffer memory should be saved inside the PLC.

All setpoints and settings must be written to the buffer memory after the power supply has been switched on.

By monitoring the request for initialization (bit 8 of BFM #27) a start-up of the RE10TC and an associated data loss can be detected.

It is strongly recommended to save the calculated PID constants in the PLC after self optimization of the RE10TC has been performed.

All settings for the RE10TC are done by software. The data is written to the buffer memory of the RE10TC using TO instructions (TO, TOP, DTO, DTOP).

Actual values are read from the RE10TC using FROM instructions (FROM, FROMP, DFROM, DFROMP).

On the following pages some guidelines are given for programming the functions of the temperature control module.

Please refer to the FX Programming Manual for detailed information about the TO and FROM instructions.

5.1 Initial settings

After the power supply of the RE10TC has been turned on the following settings should be written to the buffer memory:

- operation mode (BFM #330 to BFM #339):
Type of controller, type of analog input, type of thermocouple

You can also operate with the RE10TC base values. Then the RE10TC measurement inputs work as thermo-coupler inputs for type L and the controllers are configured as two-point controllers (only for heating).

- temperature offsets in BFM #260 to BFM #269 if needed.

After writing the settings the request for initialization (bit 12 in buffer memory address 340) must be reset. The request for initialization indicates that a start-up of the RE10TC has been performed, and that all settings must be written to the buffer memory.

This programming is not absolutely necessary for the RE10TC to operate. However, we recommend monitoring initialisation requirements (bit 8 in BFM #27), so that with skilful programming it is possible to operate a heater practically without interruption, even when short breaks in power supply to the temperature control module have the effect of a reset on the RE10TC.

5.1.1 Detection of RE10TC errors

Buffer memory address #348 offers a “watchdog” feature. During each cycle the RE10TC writes a “1” in this buffer memory address. To monitor the temperature control module, buffer memory address #348 must be reset to “0” by the PLC program, if it contains a “1”. If BFM #348 is not a “1” again after a certain period of time, then the RE10TC will no longer function correctly.

Programming example

In the following example the watchdog (BFM #348) checks the RE10TC every four seconds. If the temperature control module is working correctly and if it has entered the value “1” in buffer memory address #348, then the PLC will have set buffer memory address to “0”. If the RE10TC has not set the watchdog (BFM #348) and if the buffer memory address does not contain a “0”, then in this example output Y0 will be set to display an error message. The temperature control module has the special module address 3.



Abb. 5-1: Example for error detection

5.1.2 Writing to the control word BFM #340

This example is a suggestion for writing the buffer memory address #340 control word. The RE10TC has the special module address “3”.

Please note the following when programming:

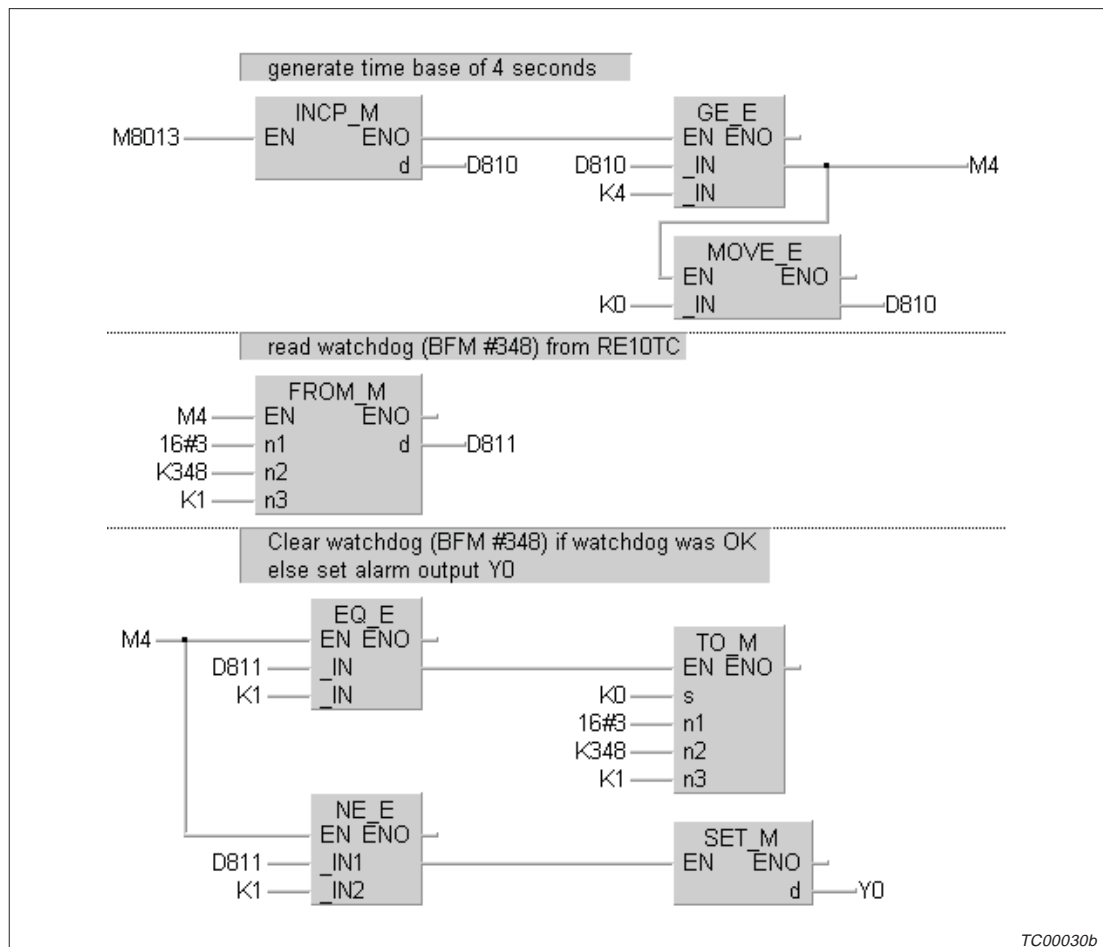
- All parts of the program which require the BFM #340 control word to be written must be programmed in accordance with the sequence illustrated below.
- These parts of the program simply set bits in register D800. The example program in figure 5-2 writes the contents of register D800 in the control word (BFM #340) of the temperature control module.

The D800 data register contains information which is to be written in the buffer memory address #340 control word. If the contents of D800 do not equal 0, then the correct status of BFM #340 will be read by the RE10TC into D801 in order to determine whether the RE10TC has fully processed all control words already sent. This is the case when BFM #340 does equal 0. If this occurs, then the content of D800 is written in the RE10TC’s buffer memory address #340, following which the contents of D800 are set to 0.

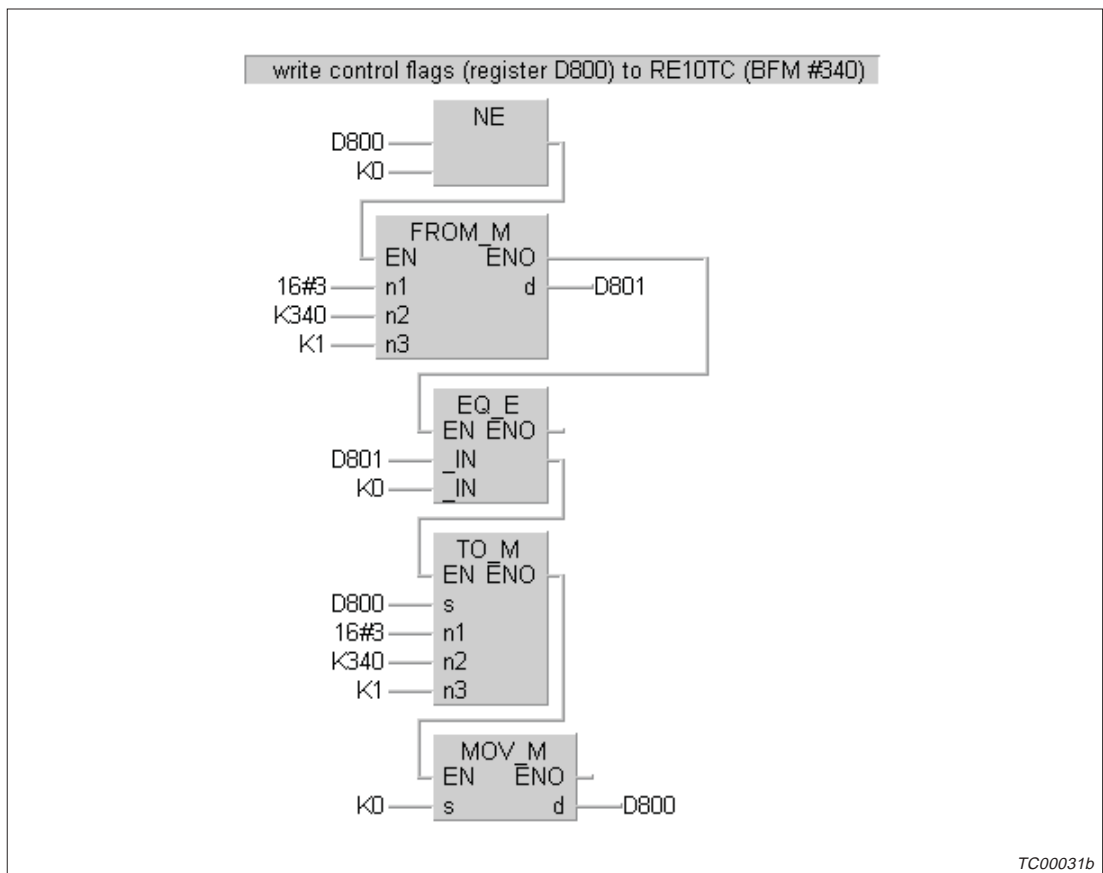

Fig. 5-2: Example of writing to the control word BFM #340

5.2 PID control

For controlling to occur, data from the FX2N base unit must be written in the memory of the temperature control module.

In the simplest case, temperature control can be activated by writing the desired temperature values (buffer memory address #120 to #129) and buffer memory address #341 ("Switching the controller on/off") in the RE10TC. Then bits 1 and 2 must be set in the control word (buffer memory address #340).

In normal circumstances however, this procedure is not sufficient, as it is necessary to adjust the controller settings to the existing control ranges.

To do this, the following parameters must be transferred to the RE10TC before controlling starts.

- Operation mode (buffer memory addresses #330 to #339)
- Control parameters : TN, TV, XP heating, XP cooling (BFM #180 to BFM #219)
- Shortest ON time for heating and cooling (BFM #220 to BFM #229)
- Cooling constant (BFM #305 to BFM #314) and starting point for cooling constant (BFM #315 to BFM #324). This parameter only applies with three point controllers.
- Leading parameters (BFM #290 to BFM #292) and threshold value for parameter switching (BFM #293).
In normal circumstances, you can also operate with the RE10TC base values. Only in specific cases is it necessary to adjust the leading parameters.
- Desired temperature values (BFM #120 to BFM #129)
- "Controller ON/OFF switching" (BFM #341)

Then bits 0, 1, 2 and 10 must be set in the control word (BFM #340). Bit 10 is only required if the leading parameters are changed.

Programming example

In the example illustrated on the following page, the RE10TC has the special module address "3". Temperature control is begun when input X1 is switched on.

The settings for

- XP heating, XP cooling (BFM #180 to BFM #199)
- TN and Tv (BFM #200 to BFM #219)
- shortest ON time for heating and cooling (BFM #220 to BFM #229)
- cooling constant (BFM #305 to BFM #314)
- cooling constant starting point (BFM #315 to BFM #324)
- operation mode (BFM #330 to BFM #339) and
- desired temperature values (BFM #120 to BFM #129)

are taken from the PLC registers D0 to D59, D60 to D109, D180 to D199 and D210 to D219 and written to the corresponding RE10TC buffer memory addresses.

The parameter "Controller ON/OFF switching" (BFM#341) is also written to the RE10TC. In this example controllers 1, 2, 3, 9 and 10 (0307H) are switched on.

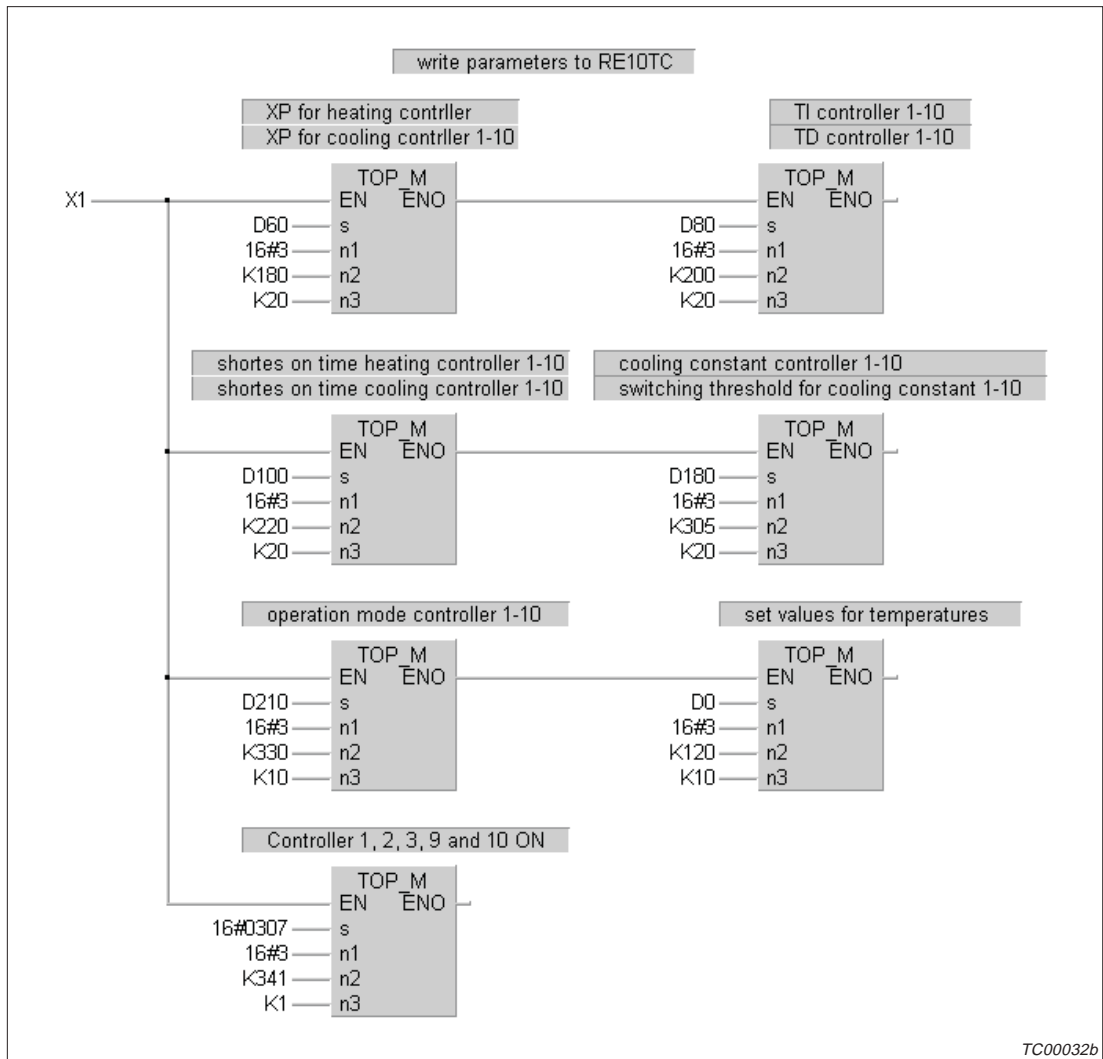

Fig. 5-3: Example for PID control

Now you must further ensure that the corresponding bits are written in the control word (BFM #340). If the program sequence (“Writing the control word BFM #340”) shown in 5.1.2 is included in your program, this can be simply carried out using the WORP instructions illustrated below. Bits 0, 1 and 2 (16#0007) are joined to the contents of register D800 as “or”-links. The contents of D800 are written in the control word (BFM #340) by the example program illustrated in 5.1.2.

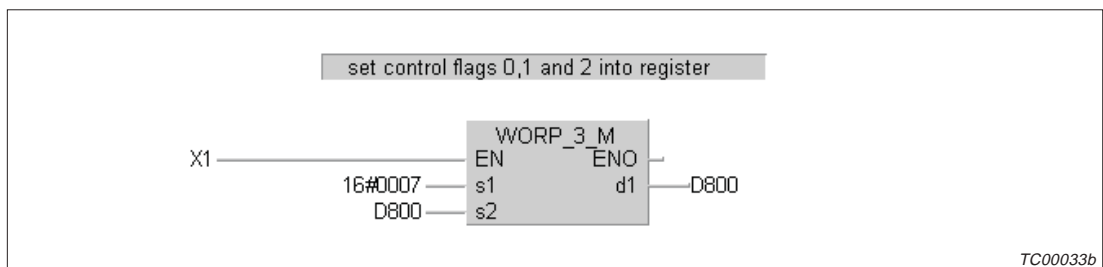

Fig. 5-4: Setting of Bits 0, 1 and 2 in D800

If the controller switched on in this example is switched off again, then the value “0” must be written in the RE10TC’s buffer memory address #341 (“Controller ON/OFF switching”). Bit 2 is then set in the control word (BFM #340).

The following diagram shows switching the temperature controllers off. In this example too, it is assumed that the program sequence in 5.1.2 for writing the control word (BFM #340) is used. The controllers are switched off by setting input X2.

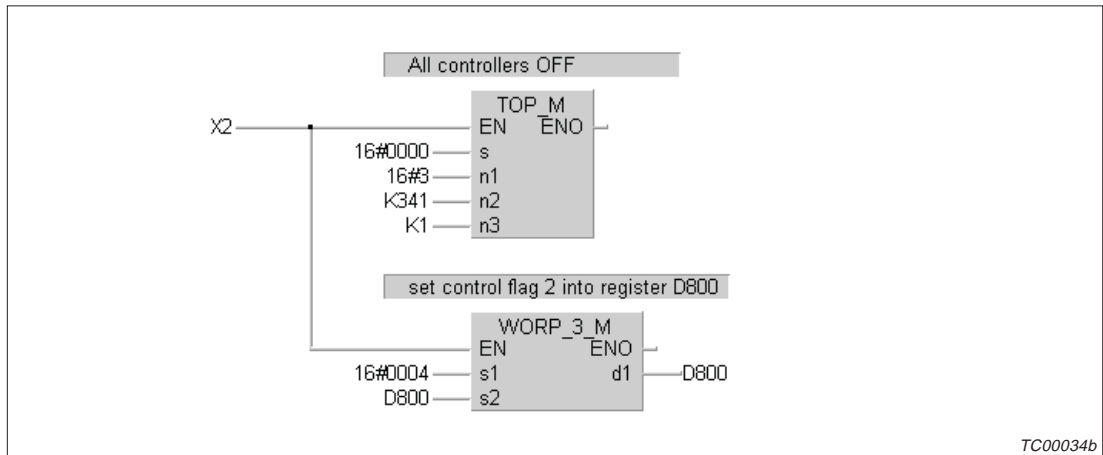

Fig. 5-5: Switching off the temperature controllers

5.2.1 Stand-by mode

The temperatures of the ten heating zones can be lowered simultaneously by activating the stand-by mode. An application e.g. is to cool down after the end of a shift.

Activation

- write the set values for the stand-by mode to the buffer memory (BFM #130 to BFM #139).
- turn bit 9 of the buffer memory address 340 ON to enter the stand-by mode.
- the set values for the stand-by mode are valid and are used as set values for the temperatures.

Deactivation

- set bit 1 of BFM #340 to end the stand-by mode and to make the set values in BFM #120 to BFM #129 valid.

5.2.2 Self optimisation (pretuning)

NOTE

| Please refer to chapter 2.1.1 before starting the self optimisation.

Select the self optimisation with or without automatic acceptance of the results by setting of the correspondend bit in the buffer memory address 340 when all conditions are be fulfilled. The results of the self optimisation can be influenced by setting bit 10 in the buffer memory addresses 330 to 339 (operation mode).

The state of the self optimisation is indicated in the buffer memory adresses 50 to 59. The bits 12 and 13 of the buffer memory address 27 indicate whether the self optimisation is in progress or finished.

When self optimisation is over, the calculated results stored in the buffer memory addresses 60 to 99 should be read to the PLC and thus saved in the case of an interruption of the power supply.

Programming examples

- Self optimisation (fig. 5-6)

Switching on input X3 starts self optimisation for controllers 1 and 2 with automatic adoption of parameters.

Firstly desired temperature values are taken from the PLC registers D0 to D9 and written in the temperature control module's buffer memory (BFM #120 to BFM #129). Then the bits for the controller being optimised (in this case controllers 1 and 2) are set in BFM #341 (Individual controller ON/OFF switching). Now bits 1 (activate desired controller values) and 7 (start self optimisation with automatic adoption of parameters) are set in register D800. Index D800 is written with the program sequence from 5.1.2 in the control word BFM #340.

Now bit 12 (end optimisation) is checked in the status word (BFM #27). Once the bit is set, self optimisation is complete and the optimised control parameters XP heating (BFM #180 to BFM #189), XP cooling (BFM #190 to BFM #199), T_N (BFM #200 to BFM #209) and T_v (BFM #210 to BFM #219) must be saved in the PLC memory, so that they will be retained even if power is switched off.

- Stopping self optimisation which is in progress (fig. 5-7)

A running self-optimisation process can be stopped using the example program shown in fig 5-7. By switching on input X4 the value "0" is entered in BFM #341 (Individual controller ON/OFF switching). Bit 2 is then set in register D800 (Individual controller ON/OFF switching). Index D800 is written with the program sequence from 5.1.2 in the control word BFM #340.

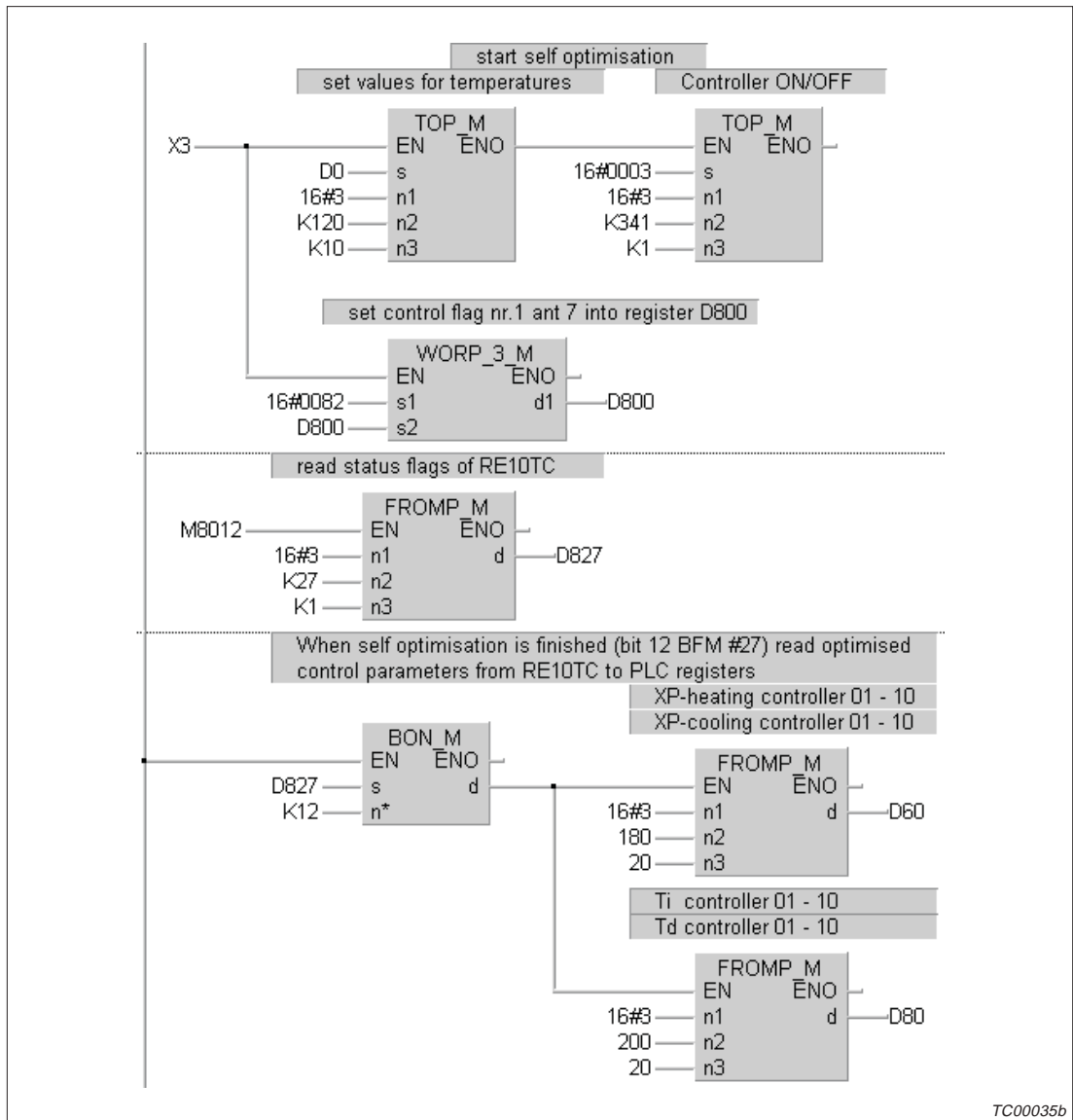

Fig. 5-6: Self optimisation

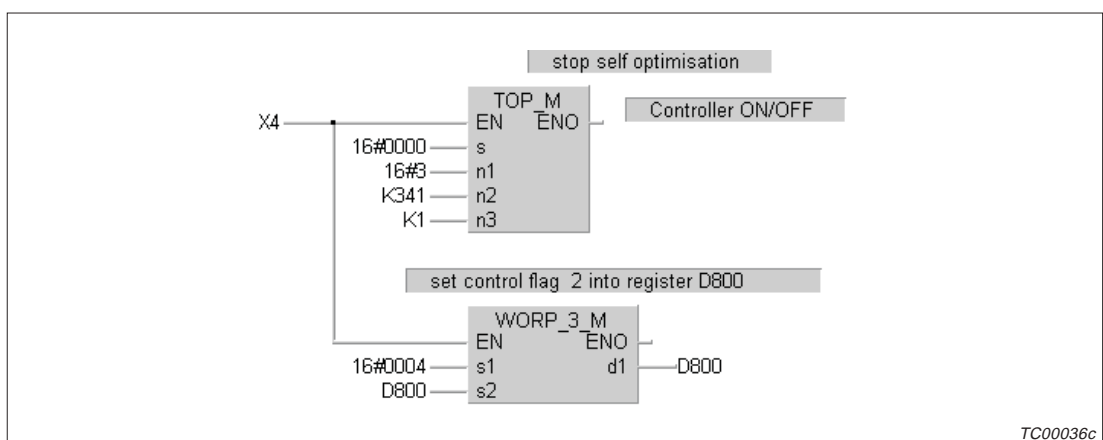

Fig. 5-7: Stopping of self optimisation

5.3 Monitoring of the sensors

If temperature sensors are set to monitor short-circuits, then the monitoring time (BFM #280 to BFM #289) must be set to a value greater than 0 for the sensors to be monitored. The desired duty cycle, by which the particular controller output will be controlled in case of a short-circuit, is written in BFM #270 to BFM #279.

When temperature sensor short circuit monitoring is switched on, then a check is run to see whether, with a duty cycle of 100% within a specified monitoring time, a rise in temperature of 2°C was recorded. If this rise in temperature is not recorded, then a bit is set in buffer memory address #26 (sensor error) and the controller output is controlled with the duty cycle which was set in "Set value for duty cycle for sensor error (BFM #270 to BFM #279)".

A sensor error recorded by temperature sensor short circuit monitoring can be re-set by switching off the controller assigned to that sensor.

5.4 Alarms

The following settings are needed for monitoring of the limits and warning values:

- setting of the limits and warning values (buffer memory addresses #140 to #179)
- selection of the type of monitoring of the lower limits and warning values (BFM #325)
- activation of the limits and warning values (BFM #342 to BFM #345)

When a limit or warning value is exceeded an alarm flag is set in the buffer memory addresses #22 to #25. These flags can be monitored by the sequence program and used for interlocks, alarm displays etc.

Bit 1 in BFM #27 indicates (if set) that the monitoring of the lower limits and warning values is active.

5.5 Monitoring of heating and leaking current

The monitoring of the heating currents has to be controlled by the sequence program of the PLC. Before the start of the monitoring the following settings must be written to the buffer memory of the RE10TC:

- Set values for the minimum heating current (BFM #294 to BFM #303)
- The maximum leaking current (BFM #304)
- Delay time for measuring of the heating current (BFM #326)
- Selection of the controller for which the heating current is to be monitored (BFM #347)

The measurement itself is controlled by the bits 4, 5 and 6 of BFM #340 (see Chapter 2.3.2). A flag in BFM #27 is turned on by the RE10TC, when the measurement of the currents is finished.

When the measurement of the heating currents has been finished, the results are stored in BFM #46. The measured values are stored in the buffer memory addresses #32 to #42.

Programming example

A single heating current monitoring is started by switching on input X5. If the heating currents are to be monitored in a cyclical fashion, then input X5 is replaced by an internal relay which sends a pulse for example every five minutes. The heating currents should however not be tested at intervals that are too short, as every heating current monitoring operation interrupts control.

Once input X5 is set, then the heating current and leakage current threshold values are transferred from the PLC to the RE10TC. Then bits are set in BFM #347 for the controllers for which the heating current is to be monitored. In this example that is controllers 1, 2 and 3. Then the 7th bit is set in register D800 (01000000 = 40H). The contents of D800 are transferred to the control word (BFM #340) with the program sequence illustrated in 5.1.2. The 7th bit (bit 6) of the control word starts heating current monitoring.

The RE10TC now checks the heating current of controllers 1, 2 and 3. Note that the controllers for which heating currents are to be monitored must be switched on before starting heating current monitoring. No heating current monitoring takes place if controllers are switched off.

By setting bit 11 in the status word (BFM #27), the RE10TC displays the end of heating current monitoring. Heating currents captured and the leakage current measured can be read off from the RE10TC (BFM #32 to BFM #42). Whether a fault was recorded in the heating currents or in the leakage current will be displayed in the heating current monitoring status word (BFM #46). In the example shown below, output Y1 will be controlled in this case.

NOTE

This example program also requires the program sequence described in 5.1.2, which writes the contents of D800 in the control word (BFM #340).

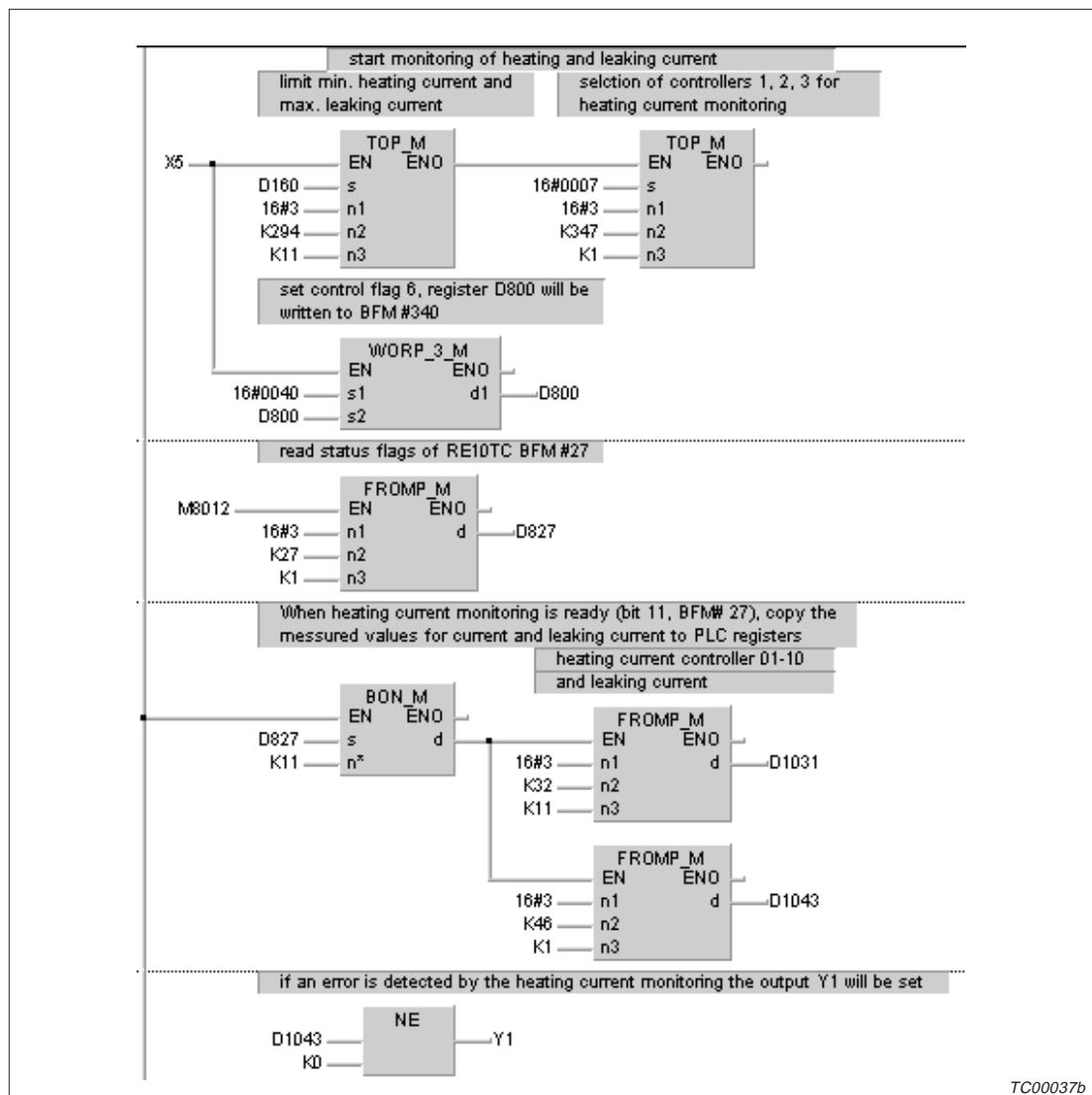

Fig. 5-8: Monitoring of heating and leaking current

A Appendix

A.1 Dimensions



Abb. A-1: Dimensions of the RE10TC

A.2 General Specifications

Item	Specifications
Operating ambient temperature	0 to 55 °C
Storage ambient temperature	-20 to +70 °C
Operating ambient humidity	10 to 85 % RH, no condensation
Protection as per EN60529	IP20
Shock resistance	98.1 m/s ² (10 g), 3 times in 3 directions
Vibration resistance	19.62 m/s ² (2 g) for continuous vibrations of 10 to 55 Hz for 120 minutes in X,Y and Z directions; 4.9 m/s ² (0.5 g) if mounted on a DIN-Rail
Isolation resistance	5 MΩ or larger by 500 V DC insulation resistance tester
Noise durability	By noise simulator of 1000 Vpp noise voltage, 1 ms noise width and 30 to 100 Hz noise frequency
Dielectric withstand voltage	1500 V AC for 1 minute
Grounding	Class 3 grounding
Operating environment	No corrosive gas. Dust protected

Tab. A-1: General Specifications for RE10TC

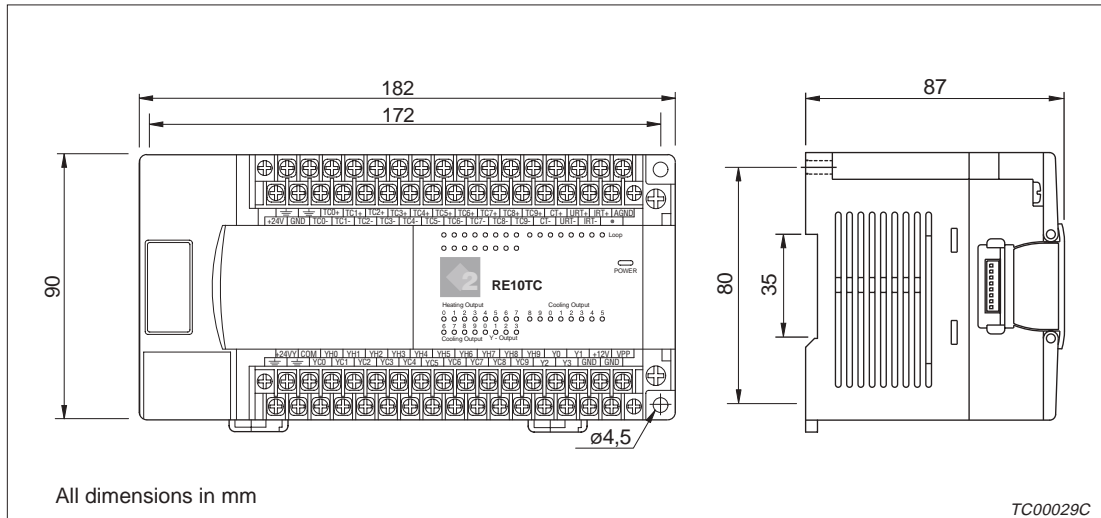
A.3 Performance Specifications

Item		Specification	
Analog inputs	Thermocouples	Number of input points	10
		Applicable types of thermocouples	J, K, L and U (Input range is from -30mV to +30mV)
		Conversion time	60 ms/channel
		Scaled temperature range	0 to 600 °C
		Digital output range	0 to 6000
		Resolution	0.1 K
		Measurement precision	± 0,5 % of range span
	Voltage input (if thermocouple inputs are used as analog inputs)	Input range	0 to 10 V DC
		Input impedance	10 kΩ or more
		Digital output range	0 to 10000
		Resolution	0.001 V
		Measurement precision	± 0.1 % of range span
		Measurement of heating current	1 input for 0 to 10 V DC; specification as for voltage input
	Reference temperature measurement	1 input with constant current source (1 mA) for KTY	
Digital outputs	Number of integrated output points	20 transistor outputs, short-circuit resistant	
	Power supply	external 24 V DC supply	
	Max. load current per output	500 mA	
Insulation	Analog input channel ↔ analog input channel	no	
	Analog input channel ↔ bus	yes	
	Analog input channel ↔ digit outputs	yes	
	Digital outputs ↔ bus	yes	
	Digital output ↔ digital output	no	
Integrated functions		PID control, pretuning, monitoring of the heating current, monitoring of user set limits	
Power supply of the measuring and control section of the module		24 V DC 100 mA, no supply from the FX PLC is necessary	
Number of occupied I/O points		8	
Weight		0.8 kg	
Dimensions (W × H × D)		mm 182 × 90 × 87	

Tab. A-2: Performance Specifications of the RE10TC

Index

A

Analog inputs	
Allocation	2 - 1
Specifications	A - 2
Terminal assignment	4 - 4

C

Current transformer	4 - 8
---------------------	-------

D

Derivative time	3 - 17
Duty cycle	
Description	3 - 17
in case of sensor fault	2 - 6

H

Heating current monitoring	
Control flags	3 - 21
Current transformer connection	4 - 8
Description	2 - 8
Monitoring ON/OFF	3 - 22
Programming	5 - 9

I

Integral time	3 - 17
---------------	--------

L

Leakage current	
Description	2 - 9
Programming	5 - 9
LEDs	4 - 1
Limits	
Description	2 - 6
Monitoring ON/OFF	3 - 22
Programming	5 - 9
Set values	3 - 16
State Indication	3 - 12

N

Neutral point wiring	4 - 6
----------------------	-------

O

Outputs for heating/cooling	
Allocation	2 - 1
Controlling by PLC	3 - 19
Indication of states	3 - 12
Specifications	A - 2

P

Power supply	
Connection	4 - 6
of the module	4 - 4
of the outputs	4 - 5

R

Reference temperature	
Sensor connection	4 - 7

S

Self optimisation	
Programming	5 - 7
Starting conditions	2 - 3

T

Temperature control	
Stand-by mode	2 - 1
Three-position control	2 - 1
Two-position control	2 - 1
Temperature sensors	
Allocation	2 - 1
Fault indication	3 - 13
Input ranges	2 - 5
Type selection	3 - 20
Three-position controller	2 - 1
Two-position controller	2 - 1

