

*Changes for the Better*

# **mitsubishi**

PROGRAMMABLE CONTROLLERS  
MELSEC-F

Industrial automation

**Elincom Group**

 European Union: [www.elinco.eu](http://www.elinco.eu)

 Russia: [www.elinc.ru](http://www.elinc.ru)

## **USER'S MANUAL**

FX<sub>2N</sub>-32ASI-M AS-interface Master Block

# **FX<sub>2N</sub>**

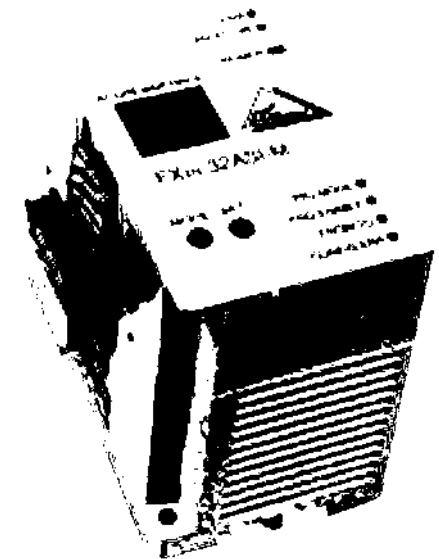

## Foreword

- This manual contains text, diagrams and explanations which will guide the reader in the correct installation and operation of the communication facilities of FX series.
- Before attempting to install or use the communication facilities of FX series this manual should be read and understood.
- If in doubt at any stage of the installation of the communication facilities of FX series always consult a professional electrical engineer who is qualified and trained to the local and national standards which apply to the installation site.
- If in doubt about the operation or use of the communication facilities of FX series please consult the nearest Mitsubishi Electric distributor.
- This manual is subject to change without notice.

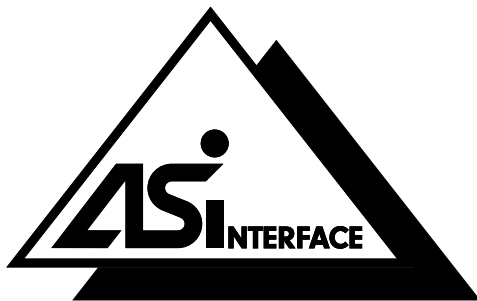

# FX<sub>2</sub>N-32ASI-M AS-interface Master Block

## User's Manual

Manual number : JY992D76901

Manual revision : G

Date : September 2007

This manual confers no industrial property rights or any rights of any other kind, nor does it confer any patent licenses. Mitsubishi Electric Corporation cannot be held responsible for any problems involving industrial property rights which may occur as a result of using the contents noted in this manual.



## **Guidelines for the safety of the user and protection of the FX<sub>2N</sub>-32ASI-M AS-interface Master Block.**

This manual provides information for the use of the FX<sub>2N</sub>-32ASI-M AS-interface Master Block. The manual has been written to be used by trained and competent personnel. The definition of such a person or persons is as follows:

- a) Any engineer who is responsible for the planning, design and construction of automatic equipment using the product associated with this manual should be of a competent nature, trained and qualified to the local and national standards required to fulfill that role. These engineers should be fully aware of all aspects of safety with regards to automated equipment.
- b) Any commissioning or service engineer must be of a competent nature, trained and qualified to the local and national standards required to fulfill that job. These engineers should also be trained in the use and maintenance of the completed product. This includes being completely familiar with all associated documentation for said product. All maintenance should be carried out in accordance with established safety practices.
- c) All operators of the completed equipment should be trained to use that product in a safe and co-ordinated manner in compliance to established safety practices. The operators should also be familiar with documentation which is connected with the actual operation of the completed equipment.

**Note :** The term ‘completed equipment’ refers to a third party constructed device which contains or uses the product associated with this manual.

## Note's on the symbols used in this manual

At various times through out this manual certain symbols will be used to highlight points of information which are intended to ensure the users personal safety and protect the integrity of equipment. Whenever any of the following symbols are encountered its associated note must be read and understood. Each of the symbols used will now be listed with a brief description of its meaning.

### Hardware warnings



1) Indicates that the identified danger **WILL** cause physical and property damage.



2) Indicates that the identified danger could **POSSIBLY** cause physical and property damage.



3) Indicates a point of further interest or further explanation.

### Software warning



4) Indicates special care must be taken when using this element of software.



5) Indicates a special point which the user of the associate software element should be aware.



6) Indicates a point of interest or further explanation.

- Under no circumstances will Mitsubishi Electric be liable responsible for any consequential damage that may arise as a result of the installation or use of this equipment.
- All examples and diagrams shown in this manual are intended only as an aid to understanding the text, not to guarantee operation. Mitsubishi Electric will accept no responsibility for actual use of the product based on these illustrative examples.
- Owing to the very great variety in possible application of this equipment, you must satisfy yourself as to its suitability for your specific application.





# Table of contents

Guideline ..... iii

## Table of contents

1. Introduction..... 1-1

- 1.1 External Dimensions and Each Part Name ..... 1-2
- 1.2 System configuration ..... 1-4
- 1.3 Applicable PLC ..... 1-5
  - 1.3.1 Controlled Maximum I/O Points of Each PLC..... 1-5
  - 1.3.2 Maximum Controlled Slave Units ..... 1-6

2. Wiring ..... 2-1

- 2.1 Caution for Wiring ..... 2-1
- 2.2 Wiring ..... 2-2

3. Specifications ..... 3-1

- 3.1 Environmental Specifications ..... 3-1
- 3.2 Power Supply Specifications ..... 3-1
- 3.3 Performance Specifications ..... 3-2

4. Master Start-Up .....	4-1
4.1 Flow of Master Start-Up.....	4-1
4.2 Off-line Phase.....	4-2
4.3 Detection Phase .....	4-2
4.4 Activation Phase.....	4-2
4.5 Start of Normal Operation.....	4-3
5. Allocation of Buffer Memories (BFMs).....	5-1
5.1 Buffer Memories (BFM) List.....	5-1
5.2 Execution Control (EC) Flags and Host Interface (HI) Flags <BFM #0 bit 0 to bit 3 and #8> .....	5-3
5.2.1 Execution Control (EC) Flags (Using FROM Instruction) <BFM #0 bit 0 to 3, BFM #8> .....	5-4
5.2.2 Host Interface (HI) Flags (Using TO Instruction) <BFM #0 bit 0 to bit 3>.....	5-7
5.3 Input and Output Data for AS-interface slave <BFM #0 bit 4 to bit 15 and #1 to #7> (Read / Write).....	5-8
5.4 Watchdog Time Setting <BFM #9> (Read / Write) .....	5-9
5.5 List of Detected Slave (LDS) <BFM #10, #11> (Read only) .....	5-10
5.6 List of Activated Slaves (LAS) <BFM #12, #13> (Read only) .....	5-11
5.7 List of Projected Slaves (LPS) <BFM #14, #15> (Read / Write).....	5-12
5.8 List of Slaves with Configuration Differences <BFM #16, #17> (Read only) .....	5-13
5.9 Command Buffer <BFM #20 to 22> (Read / Write) .....	5-14
5.9.1 Command Word List.....	5-15
5.9.2 Result List.....	5-18
5.9.3 Example Program for Command Buffer .....	5-19

5.10 Error Status <BFM #29> (Read Only) .....	5-24
5.11 ID Code <BFM #30> (Read Only) .....	5-25
6. Configuration Mode and Protected Operating Mode .....	6-1
6.1 Changing the Operation Mode .....	6-2
6.1.1 Switching to Protected Operation Mode .....	6-2
6.1.2 Switching to Configuration Mode .....	6-2
6.2 Configuration Mode .....	6-3
6.2.1 Operating the Master in Configuration Mode .....	6-3
6.2.2 Programming the Slave Address .....	6-4
6.2.3 Delete Slave Address .....	6-5
6.3 Protected Operating Mode .....	6-6
6.3.1 Operating the Master in Protected Operating Mode .....	6-6
6.3.2 Automatic Address Assignment .....	6-7
6.3.3 Manual Address Assignment .....	6-8
6.4 Displayed Message Number .....	6-9
7. Example Program .....	7-1
7.1 Content of Operation .....	7-1
7.2 System Configuration .....	7-2
7.3 Example Program .....	7-3

8. Diagnostics .....	8-1
8.1 Preliminary Checks.....	8-1
8.2 Error Checking.....	8-2
8.2.1 LED Check .....	8-2
8.2.2 Check the display message for the 32ASI-M .....	8-5
8.2.3 Check BFM #29 error status of the 32ASI-M .....	8-7
 Appendix A:	
Further Information Manual Lists.....	A-1

# 1. Introduction

The FX<sub>2N</sub>-32ASI-M (hereinafter referred to “32ASI-M”) is master block in AS-interface (Actuator-Sensor-Interface) system for FX<sub>3U</sub>, FX<sub>3UC</sub>, FX<sub>2N</sub>, FX<sub>1N</sub> and FX<sub>0N</sub> series PLCs.

## 1) Automatic Address Assignment for AS-interface Slave Units

When a slave breaks down (one of the configured slaves is not recognized), 32ASI-M can automatically allocate the slave at address 0 to the failed address.

If the non-functioning slave is replaced, the system will revert to the original slave address numbering.

## 2) Control Slave Units

The 32ASI-M can control a maximum of 31 slave units (up to 4 inputs and 4 outputs per address) on an AS-interface system. However, the maximum number of controllable slaves may be limited according to programmable controller connected. (refer to subsection 1.3.2.)

## 3) The Maximum Total Extension Distance

The maximum total extension distance is usually 100m (328' 1"). Using 2 repeaters, the maximum total extension distance is 300 m (984' 3").

## 4) I/O Refresh Time

I/O refresh time is about 5ms using maximum I/O points.

### 1.1 External Dimensions and Each Part Name

Dimensions: mm (inches) MASS (Weight): 0.2 kg (0.44 lbs)

Accessory: Special block No. label

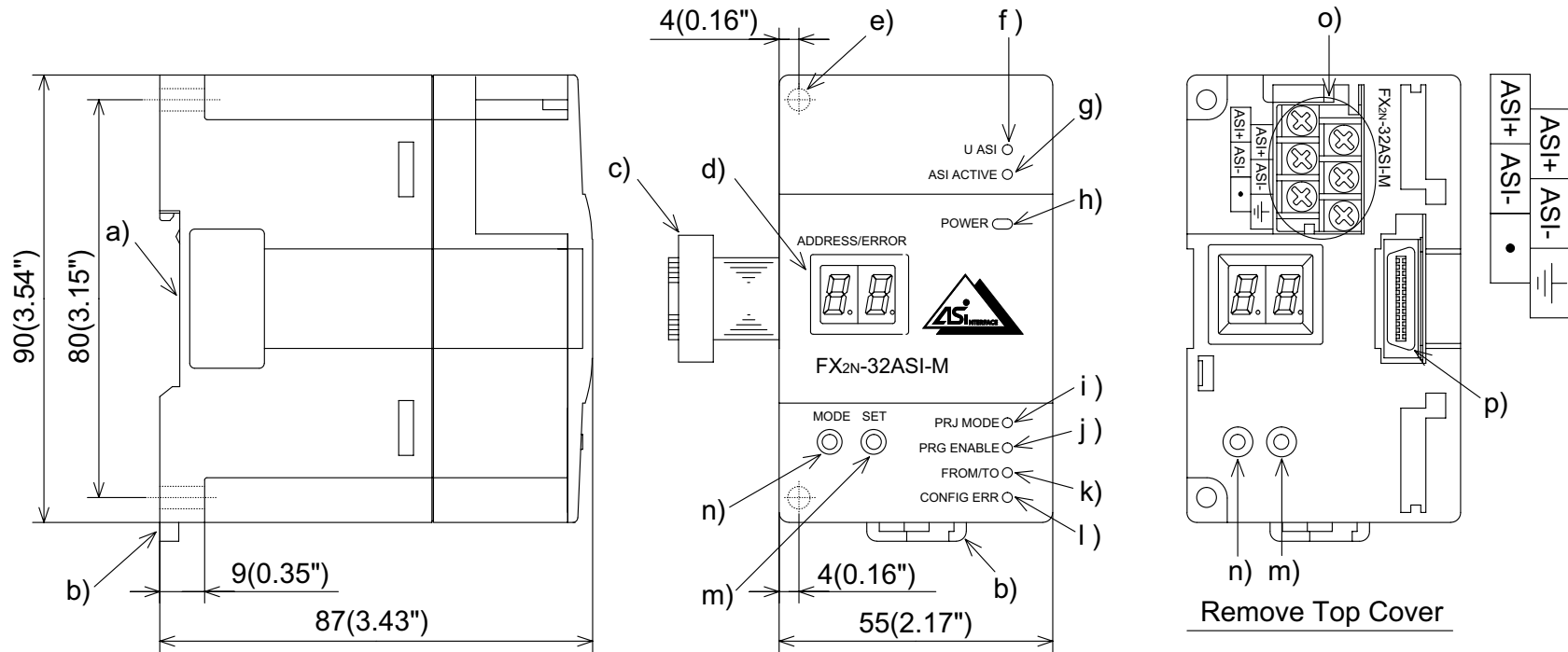

- a) Groove for DIN rail mounting (Width of DIN rail: 35 mm <1.38">)
- b) Hook for Din rail
- c) Extension cable
- d) Display: Station number, location of 32ASI-M or error code are displayed on this display.
- e) Direct mounting holes (2- $\varnothing$ 4.5 mm <0.18">)
- f) U ASI LED : Lit when external power is supplied from the AS-interface power supply.
- g) ASI ACTIVE LED : Lit when 32ASI-M is normal operation.
- h) POWER LED : Lit when the 5 V DC power is supplied from the main unit.
- i) PRJ MODE LED : Lit when 32ASI-M is in configuration mode.
- j) PRG ENABLE LED : Lit when 32ASI-M is in Automatic address programming enable.
- k) FROM / TO LED : Lit when 32ASI-M is accessed from main unit.
- l) CONFIG ERR LED : Lit when AS-interface system has a configuration error.
- m) SET button
- n) MODE button
- o) Terminal screw (M3)
- p) Extension connector

## 1.2 System configuration

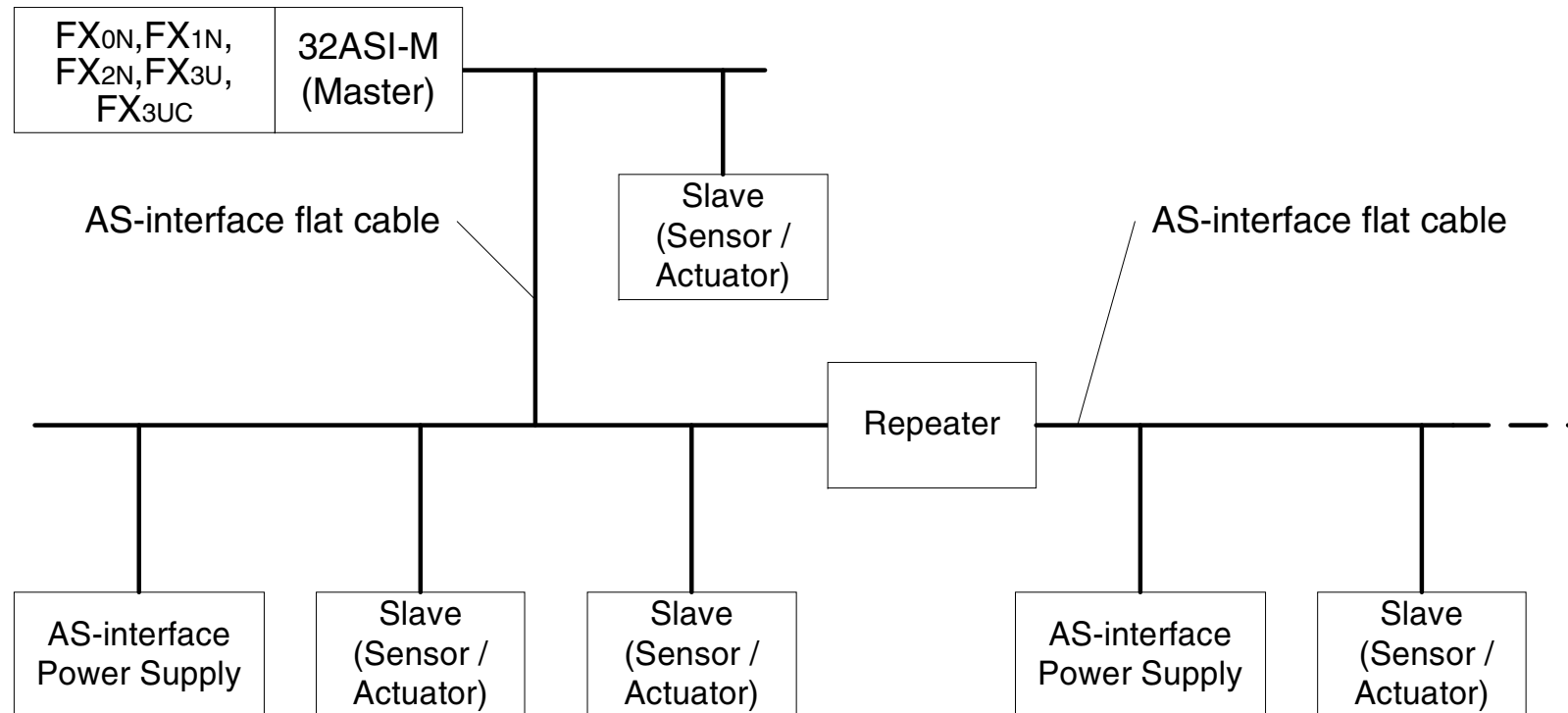

- The maximum number of controllable slaves is 31.  
However, the maximum number of controllable slaves may be limited according to the programmable controller connected.  
For this limitation, refer to subsection 1.3.2.
- Total extension distance is for 32ASI-M is 100 m (328.1')  
(Up to 2 repeaters can be used on the system. A repeater may extend the total distance an additional 100 m (328.1')).



## 1.3 Applicable PLC

32ASI-M can be connected to FX3U, FX3UC, FX2N, FX1N, or FX0N Series PLCs. The I/O control points of both the 32ASI-M and PLC CPU must not exceed the host PLC's maximum I/O point capacity.

Therefore, there is a limitation in the number of units (number of slaves) which can be controlled according to the I/O points recognized by the with PLC's CPU (occupation)\*<sup>1</sup> as follows.

\*<sup>1</sup> To use FX2N, FX1N, or FX0N Series PLCs, each AS-i slave station occupies 4 CPU I/O points.

To use FX3U, FX3UC Series PLC, each AS-i slave station occupies 8 CPU I/O points.



### Note;

An 32ASI-M module cannot be attached to an FX series PLC that is using an FX2N-16CCL-M module.

Only one 32ASI-M module can be connected to the PLC.

### 1.3.1 Controlled Maximum I/O Points of Each PLC

**Table 1.1: Controlled Maximum I/O Points of Each PLC**

PLC Type	Maximum I/O Points
FX3U, FX3UC (Ver. 2.20 or later)	384 points
FX2N, FX3UC (Ver. 2.20 or less)	256 points
FX1N	128 points
FX0N	128 points

### 1.3.2 Maximum Controlled Slave Units

The 32ASI-M can connect up to 31 slaves. However, there is a limit to the maximum number of controllable slaves according to the PLC connected.

32ASI-M calculates the number of active slaves which can be operated, and sets a limit which cannot be exceeded.



#### Note:

There is a possibility that an active slave may not operate, even if it is within the system limits.

#### 1) Calculation for the number of active slaves which can be operated

The number of active slaves which can be operated by each PLC type is calculated as follows.

##### a) FX0N, FX1N, FX2N, FX3UC (Ver. 2.20 or less)

$$\frac{\left( \text{Maximum I/O points}^{*1} \right) - \left( \text{Controlled I/O points} \right)}{4} = \text{Number of active slave} \leq 31 \text{ Slaves}$$

<include occupied points>

\*1 Maximum I/O points, as shown in table 1.1.

##### b) FX3U, FX3UC (Ver. 2.20 or later)

The value of A in Formula ① is obtained from Formula ② below. Note that when the Formula ② result is larger than 248, a value of 248 must be assigned to A.

$$\frac{A}{8} = \text{Number of active slave} = 31 \text{ Slaves} \dots\dots\dots \textcircled{1}$$

$$A = \left( \text{Maximum I/O points}^{*2} \right) - \left( \text{Controlled I/O points} \right) \dots\dots\dots \textcircled{2}$$

<include occupied points>

\*2 Maximum I/O points, as shown in table 1.1.

2) Active slaves fall into 2 limitation categories.

a) Limitation 1

A slave which can operate is allocated the lowest available active slave address.



A slave which exceeds the number of allowable active slaves cannot operate.

b) Limitation 2

One slave requires 4 bits in either the upper or lower areas of a byte. If an active in an upper or lower byte area cannot operate (through limitation 1) then any other active slaves located in the remaining 4 bits of the upper or lower byte area cannot operate either.

### Limitation Example 1



- Connected PLC: FX<sub>1</sub>N-40MR + 32ASI-M
- Controlled I/O points of PLC: 48 points <FX<sub>1</sub>N(40 points) + 32ASI-M(8 points)>  
 Number of active slaves which can be operated:  $(128 - 48) \div 4 = 20$
- Active slave addresses: 2, 3, 4, 6, 7, 8, 9, 10, 11, 12, 13, 15, 17, 19, 20, 21, 22, 23, 24, 25, 26 and 27

	Bit 15		Bit 0		
	Upper byte		Lower byte		
BFM #0	3	2	1	CE flag	 : This area represents an operative active slave address.
BFM #1	7	6	5	4	
BFM #2	11	10	9	8	 : This area represents an inoperative active slave address referring to limitation 1
BFM #3	15	14	13	12	
BFM #4	19	18	17	16	
BFM #5	23	22	21	20	
BFM #6	27	26	25	24	
BFM #7	31	30	29	28	

As these active slaves correspond only to limitation 1 in this example; The active slaves which can be operated are 2, 3, 4, 6, 7, 8, 9, 10, 11, 12, 13, 15, 17, 19, 20, 21, 22, 23, 24 and 25. (The active slaves which cannot be operated are 26 and 27 by limitation 1.)

### Limitation example 2

- Composition of programmable controller:FX1N-40MR + FX0N-40ER + 32ASI-M
- Controlled I/O points of PLC: 88 points  
 <FX1N(40 points) + FX0N(40 points) + 32ASI-M(8 points)>  
 Number of active slaves which can be operated:  $(128 - 88) \div 4 = 10$
- Active slave addresses: 2, 3, 4, 6, 7, 8, 9, 10, 11, 12, 13, 15, 17, 19, 20, 21, 22, 23, 24, 25, 26 and 27

	Bit 15		Bit 0		
	Upper byte		Lower byte		
BFM #0	3	2	1	CE flag	 : This area represents an operative active slave address.
BFM #1	7	6	5	4	 : This area represents an inoperative active slave address refering to limitation 1
BFM #2	11	10	9	8	 : This area represents an inoperative active slave address refering to limitation 2
BFM #3	15	14	13	12	
BFM #4	19	18	17	16	
BFM #5	23	22	21	20	
BFM #6	27	26	25	24	
BFM #7	31	30	29	28	

As these active slaves correspond to limitation 1 and 2 in this example; The active slaves which can be operated are 2, 3, 4, 6, 7, 8, 9, 10 and 11 as these active slaves correspond to limitation 1 and limitation 2 in this example. (The active slaves which cannot be operated are 13, 15, 17, 19, 20, 21, 22, 23, 24, 25, 26 and 27 by limitation 1. The active slave which cannot be operated is 12 by limitation 2.)

**Note:**

In this example, the maximum capacity is 10 active slaves. If the 10th active slave is changed by either of the two following methods, it can be made operative.

- When the slave allocated to address 13 is reallocated in an empty address of 14 or more, active slave address 12 can operate.
- .When the slave allocated to address 12 is re-allocated in an empty address, lower than its current address, the active slave can operate (from its new location) for example, relocation to position 5.

## 2. Wiring

### 2.1 Caution for Wiring



- 1) Do not lay signal cable near high voltage power cables or put them in the same trunking duct. Otherwise, the effects of noise or surge induction are likely to take place. Keep a safe distance of more than 100 mm (3.94") from these wires.
- 2) Connect the ground terminal on 32ASI-M with the ground terminal on the main unit of the programmable controller. Use class D (100Ω or less) grounding on the main unit.
- 3) The terminal screws for the terminal of the 32ASI-M are M3 (0.12") screws and therefore the crimp style terminal (see drawing) suitable for use with these screws should be fitted to the cable for wiring.

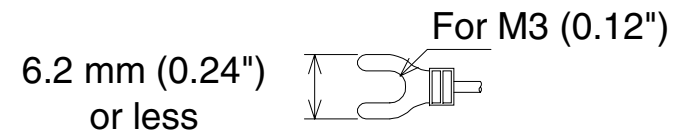
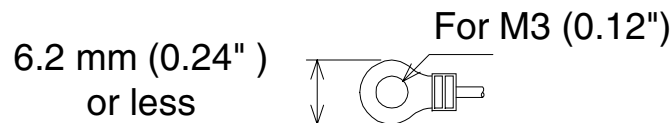

- 4) The terminal tightening torque is 0.5 to 0.8 N·m (5 to 8 kgf·cm). Tighten securely to avoid malfunction.
- 5) Cut off all phases of power source externally before installation or wiring work in order to avoid electric shock or damage to the product.
- 6) Replace the provided terminal cover before supplying power and operating the unit after installation or wiring work in order to avoid electric shock.

## 2.2 Wiring

To connect the 32ASI-M to slave units or AS-interface power supply use the AS-interface flat cable (yellow). For slaves, refer to relevant manuals.

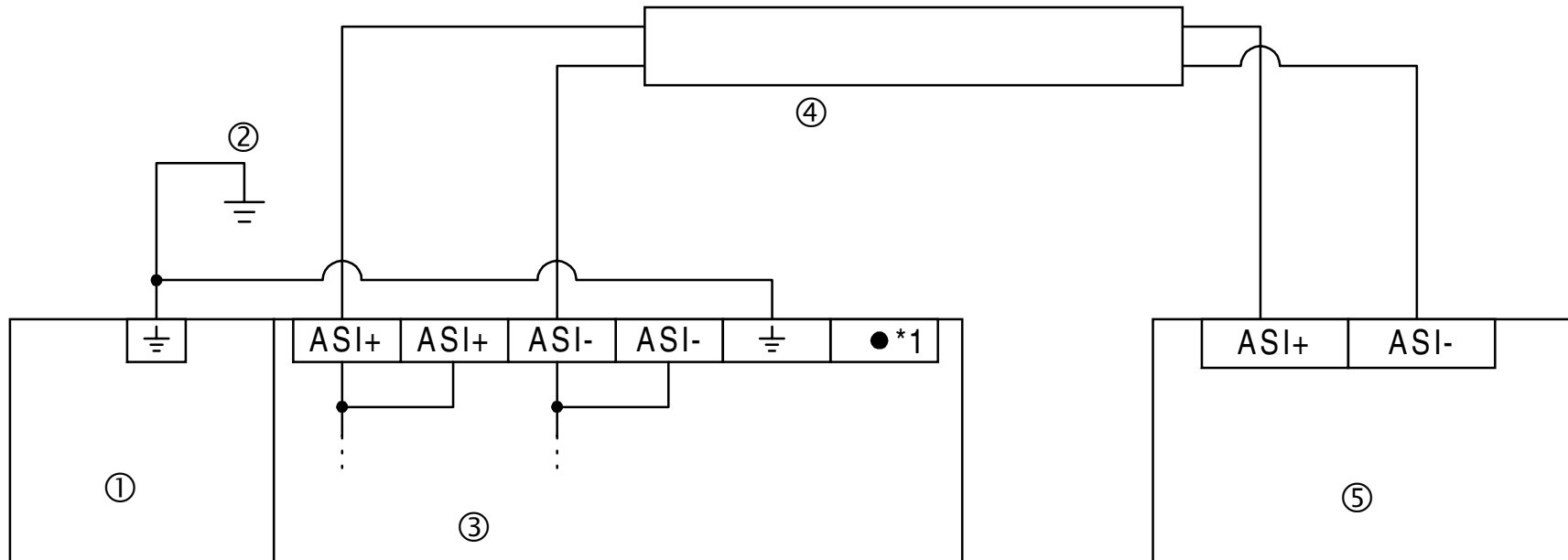

**Table 2.1: Wiring**

No.	Item Description
①	Main unit of FX <sub>0</sub> N, FX <sub>1</sub> N, FX <sub>2</sub> N, FX <sub>3</sub> U or FX <sub>3</sub> UC Series programmable controller
②	Grounding resistance of 100 Ω or less (Class D)
③	32ASI-M
④	AS-interface flat cable (yellow)
⑤	AS-interface power supply



### 3. Specifications

#### 3.1 Environmental Specifications

**Table 3.1: Environmental Specifications**

Item	Description
Environmental specifications excluding dielectric withstand voltage and complies with	Same as those of the main unit.
Dielectric Withstand Voltage	500 V AC > 1 min, tested between all points, terminals and ground
Complies with	AS-i certification (EN50295) Ver. 2.04

#### 3.2 Power Supply Specifications

**Table 3.2: Power Supply Specifications**

Item	Description
External Power Supply	AS-interface power supply
External Current Consumption	70 mA (Typical 30.5 V DC)
Internal Current Consumption	150 mA at 5 V DC

### 3.3 Performance Specifications

**Table 3.3: Performance Specifications**

Item	Description
Maximum Number of Controllable Units	Max. 31 slave units The maximum number of controllable slaves may be limited according to the programmable controller connected. (Refer to subsection 1.3.2.)
Maximum Allowable Write to the EEPROM	10,000 or below
I/O Refresh Time	Max. 5 ms (Connecting maximum I/O points)
Communication Speed	167 kbps
Communication Method	APM (Alternating Pulse Modulation) method
Communication Path Format	Bus network type (Free topology)
Total Extension Distance	Max. 100 m (328' 1") (Up to 2 repeaters can be used on the system. The total extension distance may be extended by 100 m (328' 1") for each repeater.)
Number of Occupied I/O Points	The occupied I/O points taken from the programmable controller extension bus (can be either input or output). 32ASI-M: 8 points 1 Slave; <ul style="list-style-type: none"> <li>• FX<sub>0N</sub>, FX<sub>1N</sub>, FX<sub>2N</sub>, FX<sub>3UC</sub> (Ver. 2.20 or less): 4 points</li> <li>• FX<sub>3U</sub>, FX<sub>3UC</sub> (Ver. 2.20 or later): 8 points</li> </ul>

**Table 3.3: Performance Specifications**

Item		Description
Applicable Programmable Controller		FX3U, FX3UC, FX2N, FX1N, FX0N Series PLCs The maximum number of system I/O (including 32ASI-M occupied points); <ul style="list-style-type: none"> <li>• FX3U, FX3UC (Ver. 2.20 or later): 384 or less</li> <li>• FX2N, FX3UC (Ver. 2.20 or less): 256 or less</li> <li>• FX1N, FX0N: 128 or less</li> </ul>
AS-i Version		Ver. 2.04
Communication with Programmable Controller		FROM / TO instruction
Display (7 Segment)		2 column (slave address / error code)
LED Indication	POWER	Lit when the 5 V DC power supplied from main unit.
	U ASI	Lit when external power supplied from the AS-interface power supply.
	ASI ACTIVE	Lit when AS-interface system is in normal operation.
	PRJ MODE	Lit when 32ASI-M is in configuration mode.
	PRG ENABLE	Lit when 32ASI-M is in automatic address programming enable.
	FROM / TO	Lit when 32ASI-M is accessed from main unit.
	CONFIG ERR	Lit when AS-interface system has a configuration error.

# MEMO

## 4. Master Start-Up

### 4.1 Flow of Master Start-Up

After powering on, all segments of the number displays and all LEDs light up for approximately one second. Afterwards, the LEDs display the condition of their respective flags. The 7 segment displays show the condition of the 32ASI-M.

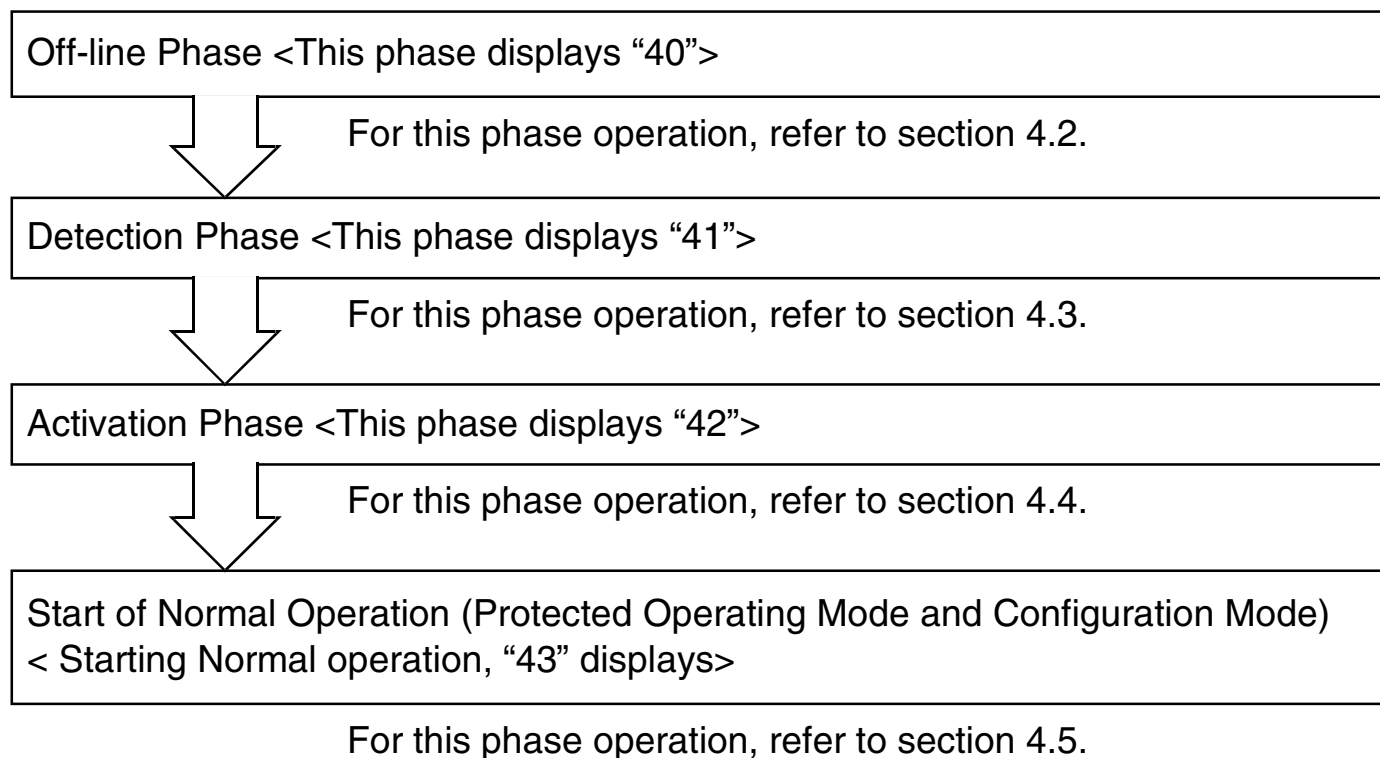

## 4.2 Off-line Phase

This phase initializes the AS-interface. There is no data communication on the AS-interface. If the AS-interface circuit is insufficiently powered (“U ASI LED” is not lit.), the master remains in the off-line phase.



### Note:

The configuration error occurs without fail when the 32ASI-M is in the off-line phase. Therefore, disregard this error when the 32ASI-M is in the off-line phase.

## 4.3 Detection Phase

This phase searches for slaves located on the 32ASI-M. The 32ASI-M remains in the detection phase until it finds at least one slave.

## 4.4 Activation Phase

This phase activates the slave(s) which 32ASI-M found in the Detection phase. This enables access to the AS-interface slaves' data connections.

## 4.5 Start of Normal Operation

In normal operation, the 32ASI-M can exchange data with all active slaves. It transmits management messages and looks for and activates newly connected slaves.

Normal operation has “Protected operating mode” and “Configuration mode”. During start-up, the unit defaults to the protected operating mode if there is an activated slave in the 32ASI-M. protected operating mode and the configuration mode can be changed by writing the command from the programmable controller or operating the button of 32ASI-M. Refer to chapter 6 for the explanation and operation of each mode.

# MEMO



## 5. Allocation of Buffer Memories (BFMs)

### 5.1 Buffer Memories (BFM) List

**Table 5.1: BFM List**

BFM No.	Description	
	FROM Instruction (Read)	TO Instruction (Write)
BFM #0	Input data from AS-interface slave 1 to 3 (see section 5.3) and part of execution control (EC) flags (see section 5.2)	Output data to AS-interface slave 1 to 3 (see section 5.3) and host interface (HI) flags (see section 5.2)
BFM #1 to 7	Input data from AS-interface slave 4 to 31 (see section 5.3)	Output data to AS-interface slave 4 to 31 (see section 5.3)
BFM #8	EC-Flags (see section 5.2)	Reserved (Read only)
BFM #9	Watchdog time setting value < × 10ms > (see section 5.4)	
BFM #10, 11	List of detected slaves (LDS) (see section 5.5)	Reserved (Read only)
BFM #12, 13	List of activated slaves (LAS) (see section 5.6)	
BFM #14, 15	List of projected slaves (LPS) (see section 5.7)	
BFM #16, 17	List of slaves with configuration differences (see section 5.8)	Reserved (Read only)
BFM #18, 19	Reserved	

If data is set in BFM #0 bit 0 - bit 3, #14, or #15, the data will be written in the 32ASI-M EEPROM. The maximum allowable write to EEPROM is 10,000 times. When creating a program, therefore do not frequently write data in the buffer memories (BFM) above.

**Table 5.1: BFM List**

BFM No.	Description	
	FROM Instruction (Read)	TO Instruction (Write)
BFM #20	Command buffer <Result> (see section 5.9)	Command buffer <Command word> (see section 5.9)
BFM #21	Command buffer <Data word 0> (see section 5.9)	Command buffer <Data word 0> (see section 5.9)
BFM #22	Command buffer <Data word 1> (see section 5.9)	Command buffer <Data word 1> (see section 5.9)
BFM #23 to #28	Reserved	
BFM #29	Module error status (see section 5.10)	Reserved (Read only)
BFM #30	Module ID code *1 (see section 5.11)	
BFM #31	Reserved	

\*1 Module ID (identification) code is K7070.



**Note:**

The data send and data receive buffers are the same buffer memory addresses (BFM #0 to #7, #9, #14, #15, #20 to #22) for use with FROM and TO instructions. This means it is not possible to check the buffer data using a FROM instruction because this instruction only reads receive buffer data.

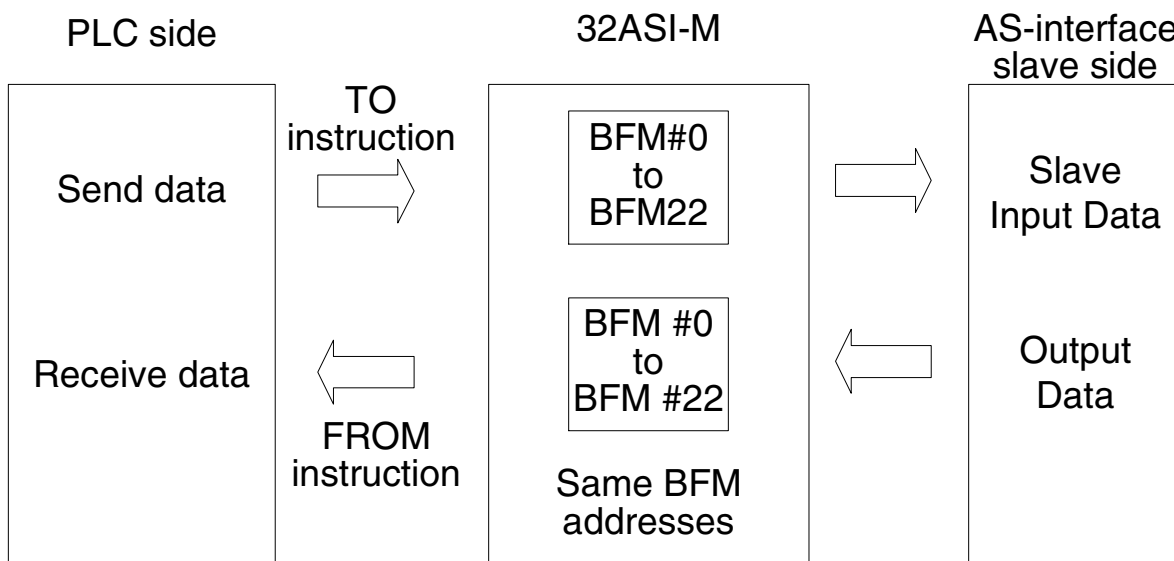

**5.2 Execution Control (EC) Flags and Host Interface (HI) Flags  
<BFM #0 bit 0 to bit 3 and #8>**

For the above BFM bits, the reading function does not use the same buffer memory address as the write function. When reading data using the FROM instruction, Execution Control (EC) flags are used. When writing data using the TO instruction, Host Interface (HI) flags are used. The information in these memory locations might be different depending upon the user program. For explanation, refer to section 5.2.1 and section 5.2.2. For BFM #0 bit 4 to bit 15, refer to section 5.3.

### 5.2.1 Execution Control (EC) Flags (Using FROM Instruction) <BFM #0 bit 0 to 3, BFM #8>

Execution control (EC) flags is status of 32ASI-M. For meaning of flags refer to the table below. For BFM #0 bit 4 to bit 15, refer to section 5.3.

**Table 5.2: Execution Control Flags**

BFM No.	Bit No.	Description	0 (OFF)	1 (ON)
BFM #0	Bit 0	Config_OK	No configuration error	Configuration error occurs
	Bit 1	APF	APO (AS-interface Power On)	APF (AS-interface Power Fail)
	Bit 2	Normal Operation Active	Normal operation	Not normal operation
	Bit 3	Configuration Active	Not configuration mode	Configuration mode
BFM #8	Bit 0	Config_OK	No configuration error	Configuration error occurs
	Bit 1	LDS. 0	Slave of address 0 is not in list of detected slaves.	Slave of address 0 is in list of detected slaves.
	Bit 2	Auto Address Available	Automatic address assignment is not allowed.	Automatic address assignment is allowed.
	Bit 3	Auto Address Assign	Automatic address assignment cannot be done.	Automatic address assignment can be done.
	Bit 4	Configuration Active	Not configuration mode	Configuration mode
	Bit 5	Normal Operation Active	Normal operation	Not normal operation
	Bit 6	APF	APO (AS-interface Power On)	APF (AS-interface Power Fail)
	Bit 7	Off-line Ready	Not off-line phase	Off-line phase
	Bit 8	Watchdog Time Out	Watchdog timer is not timed out	Watchdog timer is timed out

- 1) Config\_OK < BFM #0 Bit 0, BFM #8 Bit 0>  
This bit is for checking the configuration error flag. When a configuration error occurs in AS-interface system, this bit is ON. If this bit is ON, check whether wiring is correct or LPS is the same as LDS. For detail, refer to section 8.2.
- 2) APF <BFM #0 Bit 1, BFM #8 Bit 6>  
This bit is for checking the AS-interface Power Fail flag. When the AS-interface power supply is insufficient, this bit is ON. If this bit is ON, check the current rating of AS-interface power supply, wiring and, total distance of system. For detail of total distance, refer to section 8.1 6).
- 3) Normal Operation Active <BFM #0 Bit 2, BFM #8 Bit 5>  
This bit is for checking normal operation. When 32ASI-M is not in normal operation, this bit is ON. For normal operation, refer to section 4.5.
- 4) Configuration Active <BFM #0 Bit 3, BFM #8 Bit 4>  
This bit is for checking configuration mode. When 32ASI-M is in configuration mode, this bit is ON. When 32ASI-M is in other modes, this bit is OFF.
- 5) LDS. 0 <BFM #8 Bit 1>  
This bit is for checking the slave having address 0. The slave of address 0 is a reserved slave. When 32ASI-M has detected slave 0, this bit is ON.
- 6) Auto Address Available <BFM #8 Bit 2>  
This bit is for checking status of the automatic address assignment. When the automatic address assignment is allowed in the protected operating mode, this bit is ON.  
For automatic address assignment, refer to section 6.3.2.

## 7) Auto Address Assign &lt;BFM #8 Bit 3&gt;

This bit is for checking if the Automatic Address Assignment is possible. This is the state in which the automatic address assignment is allowed and only one of the configured slaves is not recognized in the protected operating mode. In this case, this bit is ON. For automatic address programming, refer to section 6.3.2.

## 8) Off-line Ready &lt;BFM #8 Bit 7&gt;

This bit is for checking off-line phase. When 32ASI-M is in the off-line phase, this bit is ON.

## 9) Watchdog Time Out &lt;BFM #8 Bit 8&gt;

This bit is for checking the watchdog timer. When a watchdog timer error occurs, this bit is turned ON and all outputs of the slave are turned OFF. For resetting this bit, refer to section 5.4.

### 5.2.2 Host Interface (HI) Flags (Using TO Instruction) <BFM #0 bit 0 to bit 3>

Host interface (HI) flags are for setting 32ASI-M. For BFM #0 bit 4 to bit 15, refer to section 5.3.

**Table 5.3: Host Interface (HI) Flags**

Bit No.	Description	0 (OFF)	1 (ON)
Bit 0	Off-line	0 (OFF) to 1 (ON)	32ASI-M is set into off-line phase.
		1 (ON) to 0 (OFF)	The phase sequentially shifts to normal operation.
Bit 1	Auto address enable	Auto address assignment is enabled	Auto address assignment is disabled
Bit 2	Configuration mode	0 (OFF) to 1 (ON)	32ASI-M is set into configuration mode.
		1 (ON) to 0 (OFF)	32ASI-M does not process any data.
Bit 3	Protected mode	0 (OFF) to 1 (ON)	32ASI-M is set into protected mode.
		1 (ON) to 0 (OFF)	32ASI-M does not process any data.

If data is set in BFM #0 bit 0 - bit 3, #14, or #15, the data will be written in the 32ASI-M EEPROM. The maximum allowable write to EEPROM is 10,000 times. When creating a program, therefore do not frequently write data in the buffer memories (BFM) above.

### 5.3 Input and Output Data for AS-interface slave <BFM #0 bit 4 to bit 15 and #1 to #7> (Read / Write)

One slave is composed of 4 bits. These bits are allocated in BFMs as shown in the following table. Using FROM instructions, the ON / OFF status of the bit on the input equipment is shown. Using TO instructions, the ON / OFF status of the bit on the output equipment is changed. For BFM #0 bit 0 to bit 3, refer to section 5.2.

**Table 5.4: Allocated Input and Output Data in BFMs**

BFM No. and Bit No.		Slave No. and Bit No.	
BFM #0	Bit 4 to 7	1	Bit 0 to Bit 3
	Bit 8 to 11	2	
	Bit 12 to 15	3	
BFM #1	Bit 0 to 3	4	Bit 0 to Bit 3
	Bit 4 to 7	5	
	Bit 8 to 11	6	
BFM #2	Bit 12 to 15	7	Bit 0 to Bit 3
	Bit 0 to 3	8	
	Bit 4 to 7	9	
BFM #3	Bit 8 to 11	10	Bit 0 to Bit 3
	Bit 12 to 15	11	
	Bit 0 to 3	12	
BFM #4	Bit 4 to 7	13	Bit 0 to Bit 3
	Bit 8 to 11	14	
	Bit 12 to 15	15	

BFM No. and Bit No.		Slave No. and Bit No.	
BFM #4	Bit 0 to 3	16	Bit 0 to Bit 3
	Bit 4 to 7	17	
	Bit 8 to 11	18	
	Bit 12 to 15	19	
BFM #5	Bit 0 to 3	20	Bit 0 to Bit 3
	Bit 4 to 7	21	
	Bit 8 to 11	22	
	Bit 12 to 15	23	
BFM #6	Bit 0 to 3	24	Bit 0 to Bit 3
	Bit 4 to 7	25	
	Bit 8 to 11	26	
	Bit 12 to 15	27	
BFM #7	Bit 0 to 3	28	Bit 0 to Bit 3
	Bit 4 to 7	29	
	Bit 8 to 11	30	
	Bit 12 to 15	31	



## 5.4 Watchdog Time Setting <BFM #9> (Read / Write)

The watchdog time is adjusted in 10 ms steps. Default value is 20 ( $20 \times 10 \text{ ms} = 200 \text{ ms}$ ). When this value is 0, the watchdog timer is disabled. When BFM #0 to #8 are not accessed by FROM / TO instructions, the watchdog timer begins operating.



When the watchdog time is written in BFM #9 by TO instruction, the watchdog timer is reset. At this time, 32ASI-M turns off both bit 8 of BFM #8 and bit 4 of BFM #29, and clears the data for the output in BFM #0 to # 7, so data for using all outputs has to be rewritten.



If the watchdog timer reaches its set time ( $\text{BFM \#9} \times 10 \text{ ms}$ ), a watchdog timer error occurs. At this time, both bit 8 of BFM #8 and bit 4 of BFM #29 are turned ON and all the outputs of the slaves connected to the 32ASI-M are turned off.

## 5.5 List of Detected Slave (LDS) <BFM #10, #11> (Read only)

In this list one bit is set for each slave (0 to 31) that is detected by 32ASI-M (through the start up).

When the bit is ON, the system has the slave which corresponds to the bit. If the bit is OFF, the system does not have the slave which corresponds to the bit.

**Table 5.5: List of Detected Slave (LDS)**

BFM No.	Bit No.	Slave No.
BFM #10	Bit 0	0
	Bit 1	1
	Bit 2	2
	Bit 3	3
	⋮	⋮
	⋮	⋮
	Bit 15	15

BFM No.	Bit No.	Slave No.
BFM #11	Bit 0	16
	Bit 1	17
	Bit 2	18
	Bit 3	19
	⋮	⋮
	⋮	⋮
	Bit 15	31

### 5.6 List of Activated Slaves (LAS) <BFM #12, #13> (Read only)

In this list one bit is set for each activated slave (1 to 31).

When the bit is ON, the slave corresponding to the bit is active in the system. If the bit is OFF, the slave corresponding to the bit is not active in the system.

List of active slaves are detected as follows:

- 1) Activation phase
- 2) In the configuration mode  
 LAS (List of Active Slaves) is same as LDS (List of Detected Slaves), i.e. a detected slave always becomes an active slave.
- 3) In the protected operating mode  
 LAS consists of the slave that are ON in both the LDS and PLS (List of Projected Slaves), i.e. an active slave is both a detected slave and a projected slave.

**Table 5.6: List of Activated Slaves (LAS)**

BFM No.	Bit No.	Slave No.
BFM #12	Bit 0	0
	Bit 1	1
	Bit 2	2
	Bit 3	3
	⋮	⋮
	Bit 15	15

BFM No.	Bit No.	Slave No.
BFM #13	Bit 0	16
	Bit 1	17
	Bit 2	18
	Bit 3	19
	⋮	⋮
	Bit 15	31

## 5.7 List of Projected Slaves (LPS) <BFM #14, #15> (Read / Write)

In this list one bit is status for each expected slave (1 to 31) in 32ASI-M. If the bit is ON, the slave corresponding to the bit is activated in the system. If the bit is OFF, the slave corresponding to the bit is not activated in the system.

**Table 5.7: List of Projected Slaves (LPS)**

BFM No.	Bit No.	Slave No.	BFM No.	Bit No.	Slave No.
BFM #14	Bit 0	0	BFM #15	Bit 0	16
	Bit 1	1		Bit 1	17
	Bit 2	2		Bit 2	18
	Bit 3	3		Bit 3	19
	:	:		:	:
	:	:		:	:
	Bit 15	15		Bit 15	31

If data is set in BFM #0 bit 0 - bit 3, #14, or #15, the data will be written in the 32ASI-M EEPROM. The maximum allowable write to EEPROM is 10,000 times. When creating a program, therefore do not frequently write data in the buffer memories (BFM) above.

## 5.8 List of Slaves with Configuration Differences <BFM #16, #17> (Read only)

In this list, both LDS (List of Detected Slaves) and LPS (List of Projected Slaves) are compared to LAS (List of Active Slaves). The bit will be ON if there is a discrepancy between the three lists.

**Table 5.8: List of Slaves with Configuration Differences**

BFM No.	Bit No.	Slave No.
BFM #16	Bit 0	0
	Bit 1	1
	Bit 2	2
	Bit 3	3
	:	:
	:	:
	Bit 15	15

BFM No.	Bit No.	Slave No.
BFM #17	Bit 0	16
	Bit 1	17
	Bit 2	18
	Bit 3	19
	:	:
	:	:
	Bit 15	31

## 5.9 Command Buffer <BFM #20 to 22> (Read / Write)

By using the Command Buffer, programmable controller is able to instruct the 32ASI-M as shown in table 5.9. If the programmable controller writes data in Command Word (BFM #20), the 32ASI-M reads the Command Word and, if necessary, one or two Data Words (BFM #21,22). The result (BFM #20) is set to “pending”. If the desired command is executed by the 32ASI-M, the result is set and, the value is no longer “Pending”. Results with data are transmitted in Data Word 0 and 1 (BFM #21, 22). For example program, refer to subsection 5.9.3.

### 5.9.1 Command Word List

**Table 5.9: Command word list**

Command Word	Description	Using location
0	No command	
1 to 31	Writes data word 0 (BFM #21) to the actual parameter* <sup>1</sup> in the AS-interface slave n (n = "Command Word"). And reads the actual parameter form AS-interface slave n to data word 0.	Normal operation
32	No command	
33 to 63	Reads the actual parameter* <sup>1</sup> from AS-interface slave n (n = "Command Word" - 32) to data word 0. <Default value is "F (Hex)".>	Normal operation, Off-line phase
64	No command	
65 to 95	Writes data word 0 to permanent parameter* <sup>1</sup> in the AS-interface slave n (n = "Command Word" - 64).	Normal operation, Off-line phase
96	No command	
97 to 127	Reads the permanent parameter* <sup>1</sup> from AS-interface slave n (n = "Command Word" - 96) to data word 0. <Default value is "F (Hex)".>	Normal operation, Off-line phase
128 to 159	Reads actual configuration* <sup>2</sup> from AS-interface slave n (n = Command Word - 128) to data word 0. <No slave is "FF (Hex)".>	Normal operation
160	No command	
161 to 191	Writes data word 0 to permanent configuration* <sup>3</sup> in the AS-interface n (n = Command Word - 160).	Configuration mode

**Table 5.9: Command word list**

Command Word	Description	Using location
192	No command	
193 to 223	Reads the permanent configuration* <sup>3</sup> from AS-interface slave n (n = Command Word - 192) to data word 0. <No slave is "FF (Hex)".>	Normal operation, Off-line phase
224	Reads the counter of APF from 32ASI-M to Data Word 0. And clear this value. (AS-interface Power Fail)	Normal operation
225 to 255	Reads counter of erroneous answers from AS-interface slave n to Data Word 0. And clear this value. (n = Command Word - 224)	Normal operation
256	Change AS-interface slave (LPS) with address n to m. (n = Data Word 0, m = Data Word 1).	Configuration mode, Off-line phase
257	Store actual AS-interface configuration <This command copies LAS (BFM #12, #13) to LPS (BFM #14, #15). And store actual configuration to permanent configuration, too.>	Configuration mode
259	Store actual AS-interface parameters to permanent configuration.	Normal operation, Off-line phase
260	Read list of corrupted slaves from 32ASI-M to Data Word 0 and 1, And clear this list.	Normal operation, Off-line phase



- \*1 The meaning of this parameter is slave's parameter bits.
- \*2 The meaning of this parameter is slave's parameter bits. This contains the actual copies of the input/output configuration and the identification code of all slaves, determined by reading this data from the slaves. The configuration data of inactive slave is set to default values ("FF <Hex>").

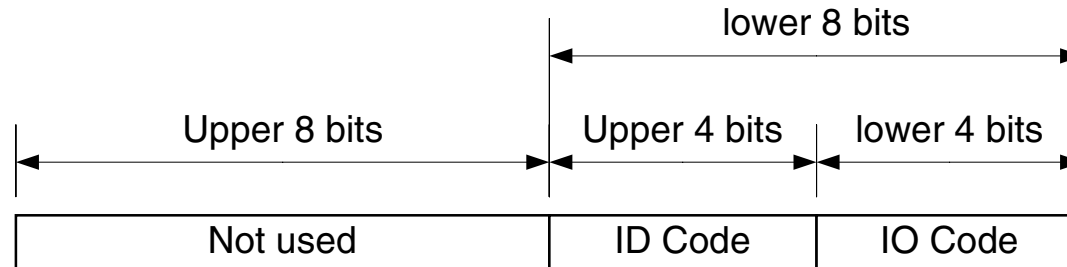

- \*3 This contains the projected input/output configuration and identification code of all slaves determined by the slave configuration of the 32ASI-M using the Command Word "161 to 191" or by the Command Word "257". The permanent configuration data of slaves that are not projected shall be set to default values ("FF <Hex>"). This data is stored in EEPROM.

## 5.9.2 Result List

**Table 5.10:Results list**

Results Value	Description
0	Command did not execute.
1	OK (Command executed.)
2	The address of the Slave which wants to change does not exist.
3	A slave already exists in address 0.
4	This address already has a slave.
5	This slave cannot be deleted.
6	This slave address cannot be set.
7	The slave address cannot be written to the slave's EEPROM.
8	Command Word pending
9	The Command Word not recognized.
10	The value of Data Word exceeds the range of setting.

### 5.9.3 Example Program for Command Buffer

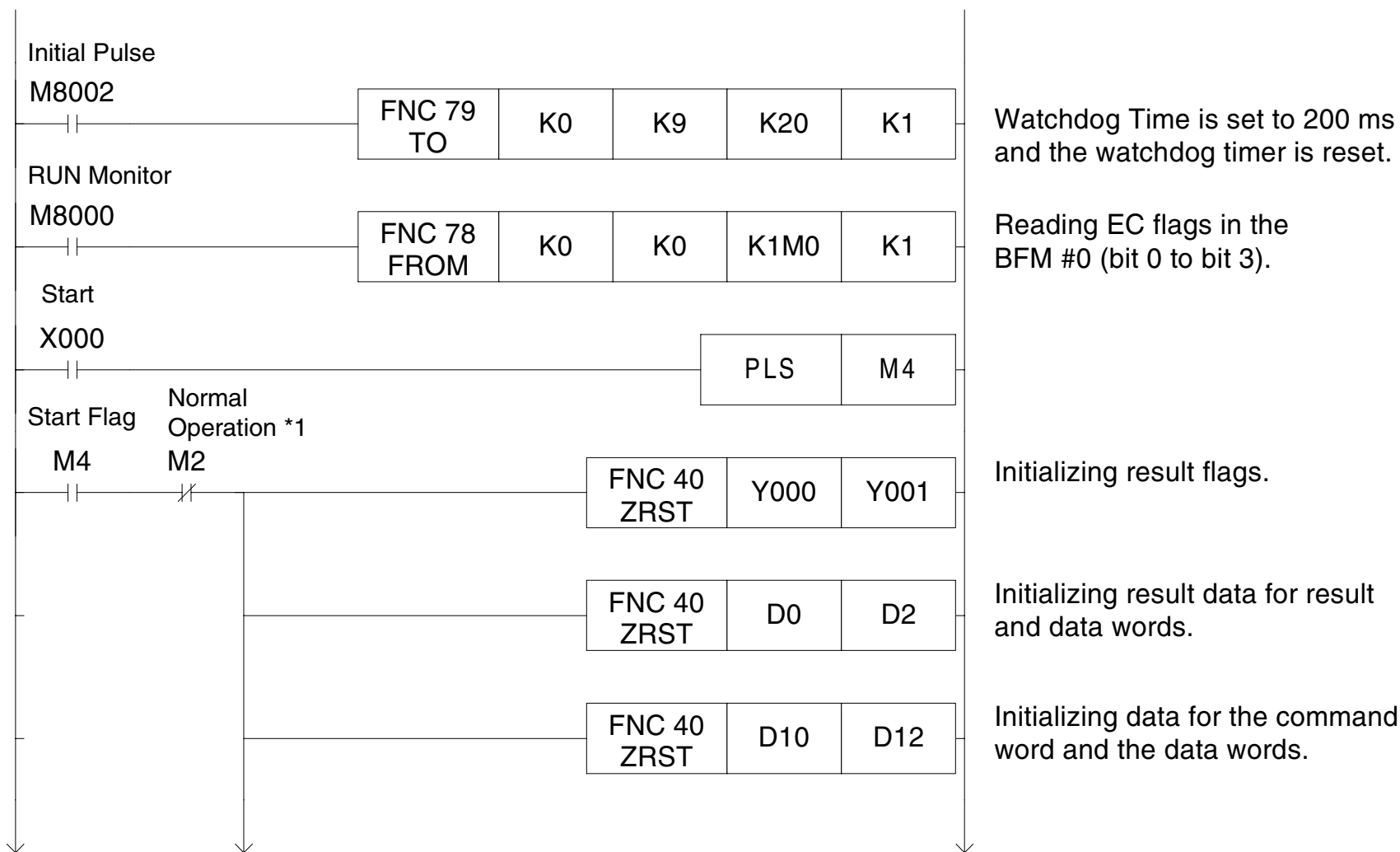

\*1 If operating in off-line phase, this contact is not necessary.

Continued.....

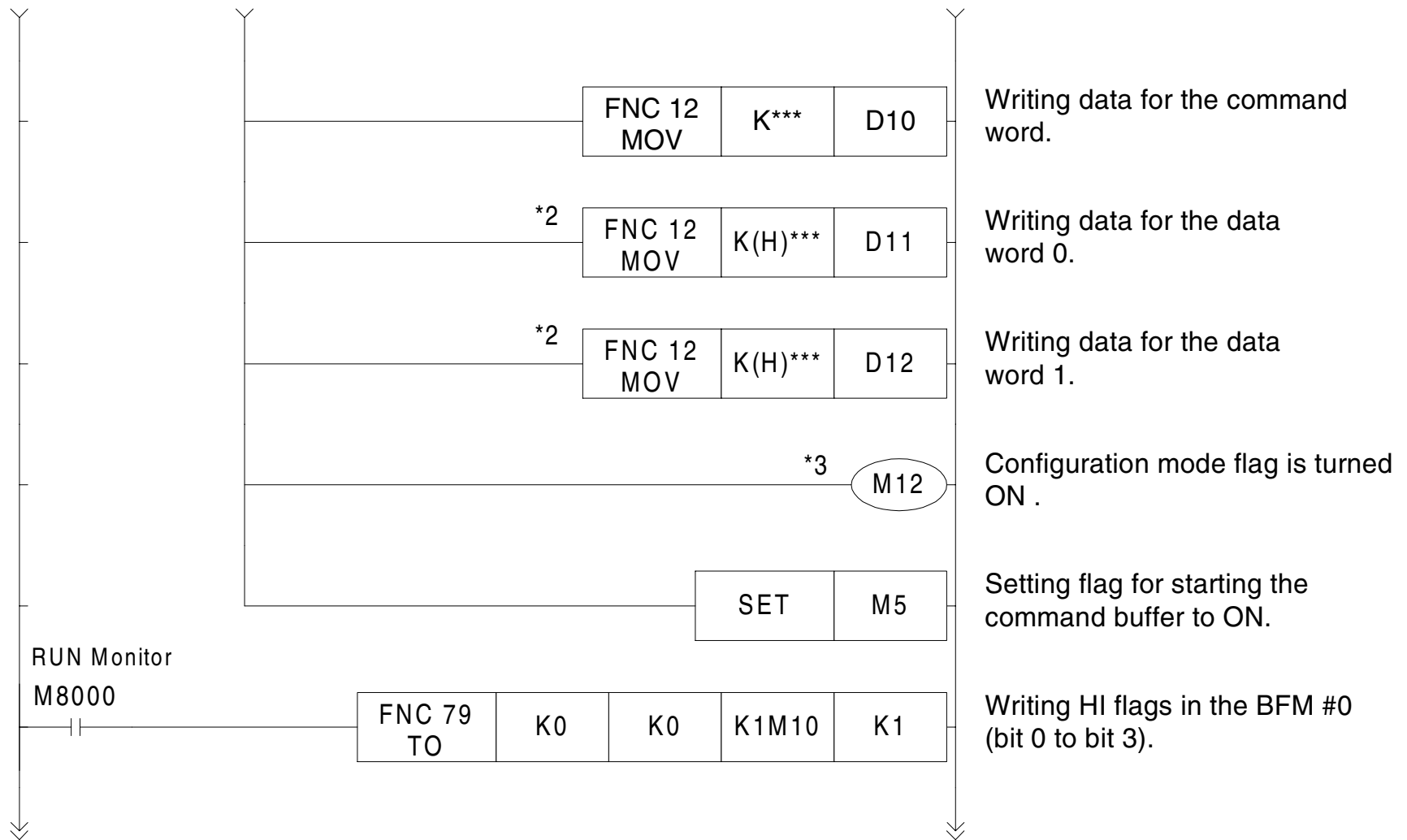

\*2 If using command does not need to write the data word, this instruction is not necessary.

\*3 If operating in protected operating mode, this contact is not necessary.

Continued.....

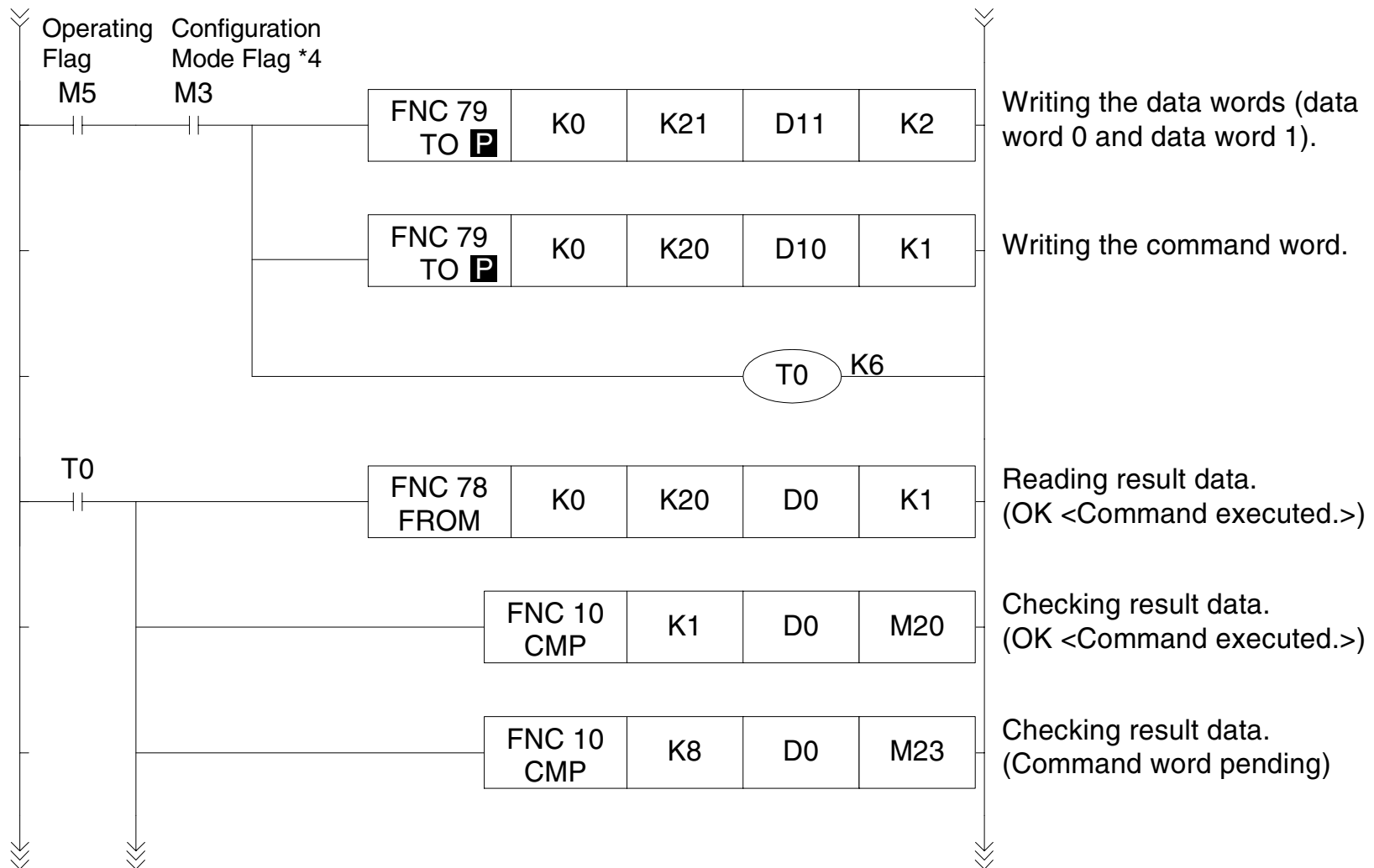

\*4 If operating in protected operating mode, this contact is not necessary.

Continued.....

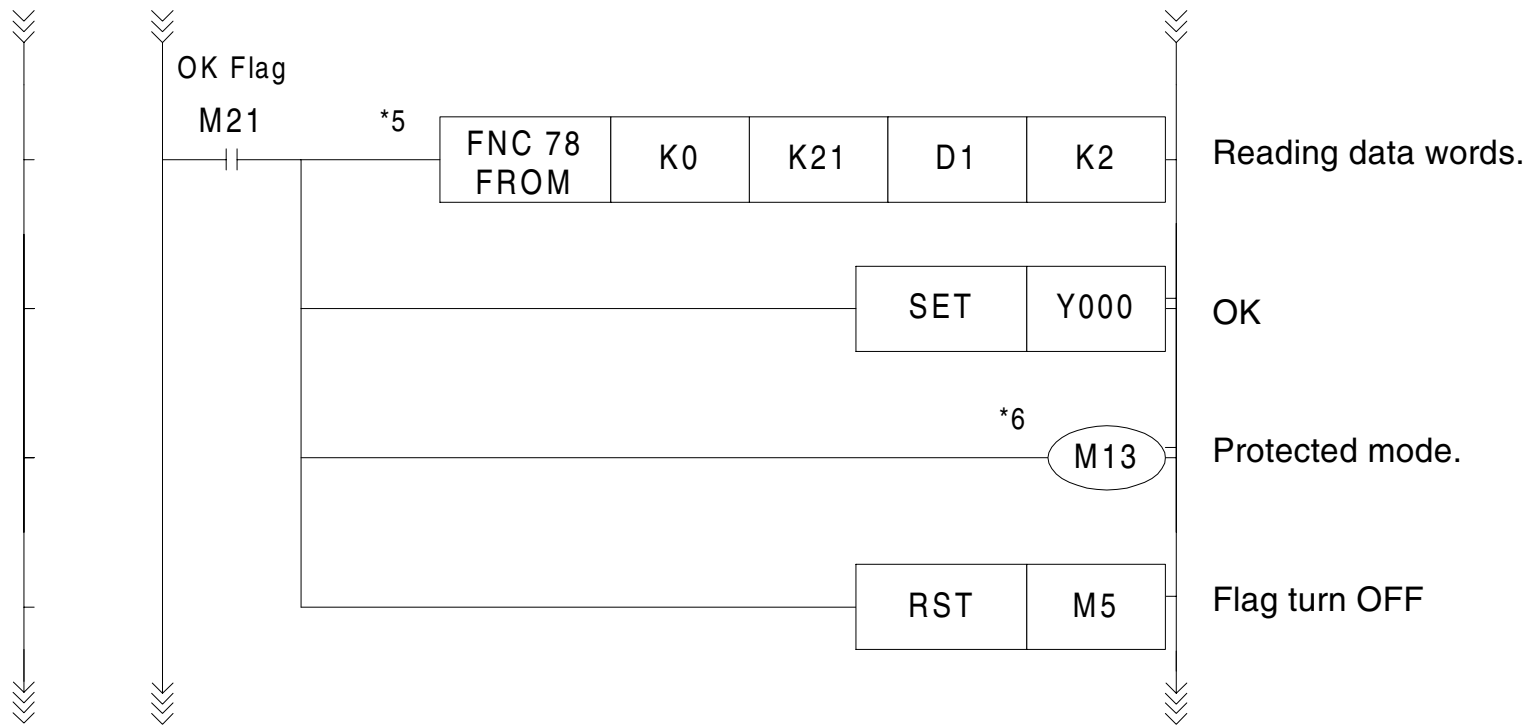

\*5 If using command does not need to read the data word, this instruction is not necessary.

\*6 If operating in protected operating mode, this contact is not necessary.

Continued.....

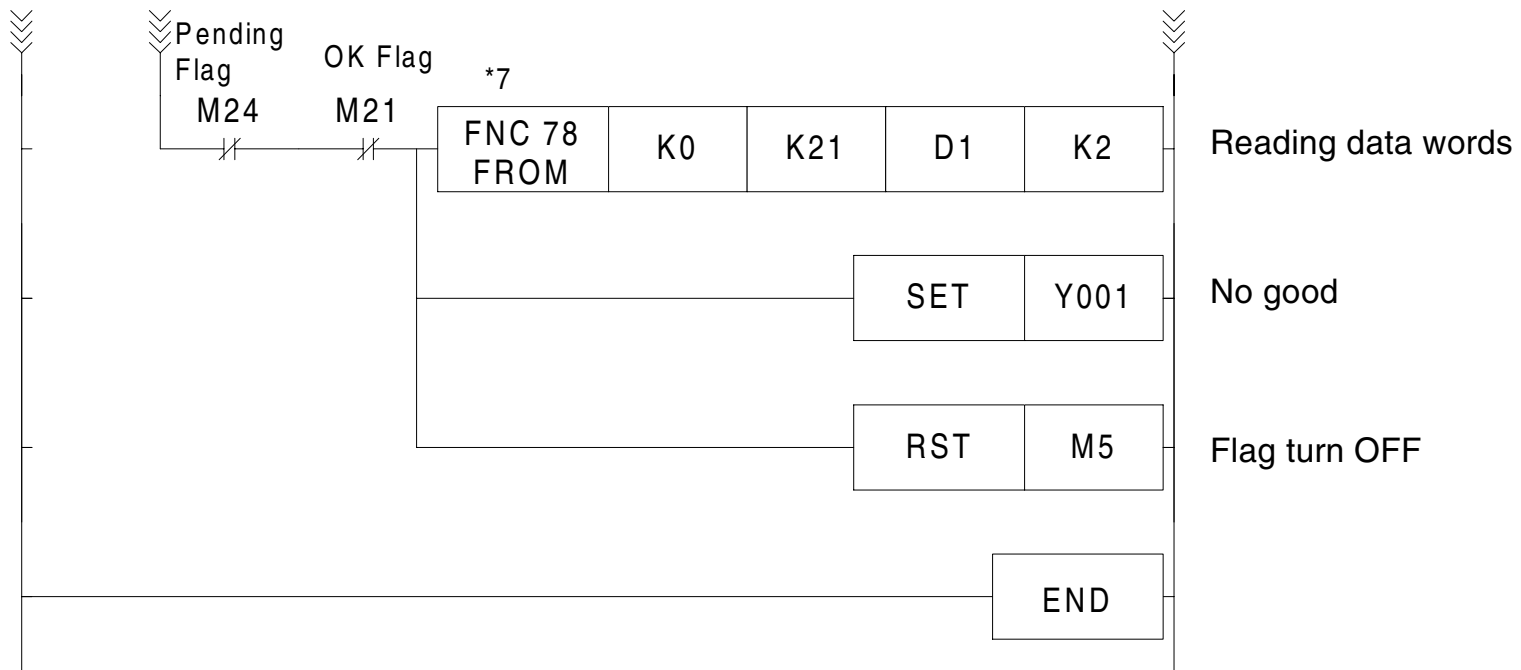

\*7 If using command does not need to read the data word, this instruction is not necessary.

## 5.10 Error Status <BFM #29> (Read Only)

BFM #29 indicates error status of 32ASI-M.

**Table 5.11: Error Status**

Bit No.	Description	0(OFF)	1(ON)	Check Points
Bit 0	General Error	No general error	This bit is ON if one or more error bits (1 to 4) are ON.	Check Bit 1 to 4 in BFM #29.
Bit 1	Config_OK	No configuration error	Configuration error occurs	Check whether wiring is correct or LPS is the same as LDS. For detail, refer to section 8.2.
Bit 2	APF	APO (AS-interface Power On)	APF (AS-interface Power Fail)	Check the current rating of AS-interface power supply, wiring and, total distance of system. For detail of total distance, refer to section 8.1 6).
Bit 3	Hardware Error	No hardware error detected	Hardware error occurs	Please contact a service representative.
Bit 4	Watchdog Error	No watchdog error	Watchdog error occurs	See section 5.4
Bit 5 to 15	Reserved			



## 5.11 ID Code <BFM #30> (Read Only)

The identification code for a 32ASI-M is read by using the From instruction. The identification code for the 32ASI-M is K7070. By reading this identification code, the user may create built-in checking routines to check whether the physical position of 32ASI-M matches to that software.

# MEMO

## 6. Configuration Mode and Protected Operating Mode

This chapter explains the operation of each mode. The mode can be changed by operating the switch on the 32ASI-M or by setting (BFM #0 bit 2,3) from the programmable controller. For BFM #0 refer to section 5.2.2.



### Note:

The switch on the 32ASI-M can be disabled to prevent mis-operation. The mode can still be changed by a command from the programmable controller. Even when the switch on the 32ASI-M is disabled, it can be operated when in off-line phase.

## 6.1 Changing the Operation Mode

### 6.1.1 Switching to Protected Operation Mode

The configuration mode is ended by pressing the “MODE” button. The mode changes to protected operating mode. At this time, 32ASI-M follows these rules for pressing the “MODE” button:

- Less than 5 seconds  
32ASI-M exits the configuration mode without copying the configuration to setpoint configuration.
- More than 5 seconds  
32ASI-M exits the configuration mode simultaneously copying the configuration to setpoint configuration. At this time, 32ASI-M stores this configuration to LPS, and stores the actual configuration to permanent configuration, too.



#### **Note:**

If the system recognizes a slave with address 0 on the AS-interface, it can not leave the configuration mode.

### 6.1.2 Switching to Configuration Mode

The Protected operation mode is ended by pressing the “MODE” button for more than 5 seconds. The mode changes to Configuration mode.

## 6.2 Configuration Mode

This mode is for setting the slave address number.

### 6.2.1 Operating the Master in Configuration Mode

In the configuration mode, the green “PRJ MODE LED” lights up and the following is done.

- 1) For active slave - all recognized slave are activated with the exception of slave 0 when desired and actual configurations do not match.
- 2) Displayed message  
32ASI-M displays all slaves entered in the list of detected slave (LDS) at a speed of two per second. If the display is empty, the list is empty, i.e. no slaves were recognized.

## 6.2.2 Programming the Slave Address

This operation assign an available address to slave with address 0.

- 1) The addresses of all recognized slaves are displayed one after the other.
- 2) To display the next higher available operating address, press the “SET” button. Each time pressing the “SET” button, the next available address is displayed.  
If “SET” or “MODE” button is not pressed for 10 seconds or more, 32ASI-M returns to the state of the display of 1).
- 3) Set the displayed address as the target address by pressing the “SET” button for more than 5 seconds.
- 4) The address display blinks.
- 5) Pressing the “SET” button again reprograms a connected slave with address 0 to the blinking address.
- 6) If error code did not display, the displays the list of detected slaves again as described. If error code displayed, see Section 6.4.
- 7) For the operation of a set end, refer to 6.1.1.

### 6.2.3 Delete Slave Address

This operation assign address 0 to a recognized slave.

- 1) The address of all recognized slave are displayed one after the other. After pressing and releasing the “SET” button, 32ASI-M displays the next available address.
- 2) Display the deleted Slave address.
- 3) Pressing “SET” button for more than five seconds while the slave address which wants to be deleted displayed, this slave is reprogrammed to address 0 again, and the display shows “00”.
- 4) When releasing the button, the display continues to display the list of detected slaves.

## 6.3 Protected Operating Mode

### 6.3.1 Operating the Master in Protected Operating Mode

In the protected operating mode, the green “PRJ MODE LED” lights off. And, the following is done.

1) For active slave

Only slaves that are entered on the list of projected slaves (LPS) and whose actual configurations match the setpoint configurations will be activated.

2) Displayed message

The display is either blank or displays the address of faulty assignment.

If the “SET” button is pressed in protected operating mode while there is not actual configuration error, the last slave address which caused an configuration error is displayed, or “39” is displayed. For error and “39”, refer to section 6.4.



### 6.3.2 Automatic Address Assignment

The automatic address programming is 32ASI-M allocate the address which automatically fails in address 0 when one of the configured slaves is not recognized in the protected operating mode. For automatic address programming, the following requirements are necessary.

- a) The 32ASI-M is necessary in protected operating mode. <BFM #0 bit 2 and bit 3 is OFF>
- b) The automatic address assignment is allowed. <BFM #8 bit 2 is ON>
- c) Only one of the configured slaves is not recognized. <BFM #8 bit1 is ON>

When these requirements are fulfilled, “PRG ENABLE” LED on the 32ASI-M light up and a slave with address 0 will be automatically assigned the operating address of the missing slave.



#### Note;

If the two slaves have different configuration data (different slave type), the automatic address assignment is not executed.

### 6.3.3 Manual Address Assignment

If several slaves fail, they cannot be replaced automatically by the 32ASI-M. Set their necessary addresses manually. If you do not want to set their addresses via programmable controller, you can set them with the keys and the display. In the protected operating mode, wrong assignments are displayed as errors.

- 1) By pressing the “SET” button, you can display all faulty assignments one after the other.
- 2) By pressing the “SET” button for more than 5 seconds, you can select the currently displayed address as a potential target address, and the display starts to blink.
- 3) If the faulty slave was previously replaced by a slave with address 0, the new slave can now be programmed for the blinking address by pressing the “SET” key again. As a requirement, the new slave’s configuration data must match the configuration data for the blinking address.
- 4) After the address has been successfully set, the next faulty assignment is displayed or the display erased. otherwise, the system displays an error. For error information, refer to section 6.4.

## 6.4 Displayed Message Number

The following number is displayed on the seven segment display.

**Table 6.1: Displayed Message Number**

No.	Description
0 to 31	Slave number
39	The last slave address which caused a configuration error is nothing
40	32ASI-M is in off-line phase
41	32ASI-M is in detection phase
42	32ASI-M is in activation phase
43	32ASI-M starts normal operation
70,72 to 76	Hardware error: Please contact a service representative.
80	Recognized slave address 0, 32ASI-M cannot finish the configuration mode.
81	General error while changing a slave address
82	32ASI-M is set in the button operation prohibition from PLC.
88	32ASI-M is starting.
90	Error while changing a slave address in protected operating mode; No slave with address 0 present
91	Error while changing slave address; Target address is already occupied
92	Error while changing slave address; New address could not be set
93	Error while changing slave address; New address could only be stored volatile memory in the slave.

**Table 6.1: Displayed Message Number**

No.	Description
94	Error while changing a slave address in protected operating mode; Slave has wrong configuration information
95	Error while changing a slave address in protected operating mode; The address where the configuration error occurs is a slave of taking the place of a missing slave.

## 7. Example Program

This program example exchanges information on I/O with the slave with the system configuration below.

### 7.1 Content of Operation

- 1) X010 to X013 of the programmable controller is output to output-data in the slave 4.
- 2) X014 to X017 of the programmable controller is output to output-data in the slave 5.
- 3) Input-data on the slave 4 is output Y010 to Y013 of the programmable controller.
- 4) Input-data on the slave 5 is output Y014 to Y017 of the programmable controller.

**Note:**

Even when the configuration error occurs, the I/O control is done to an active slave.

## 7.2 System Configuration

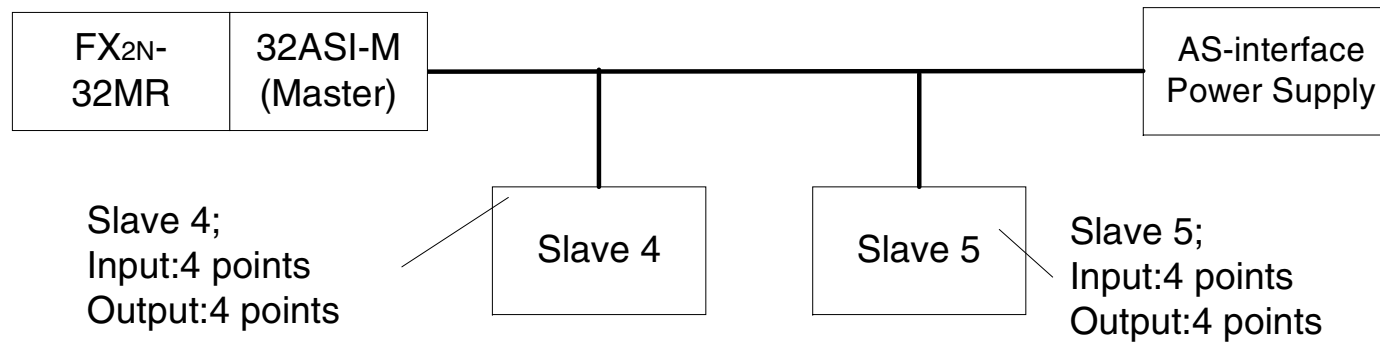

### 7.3 Example Program

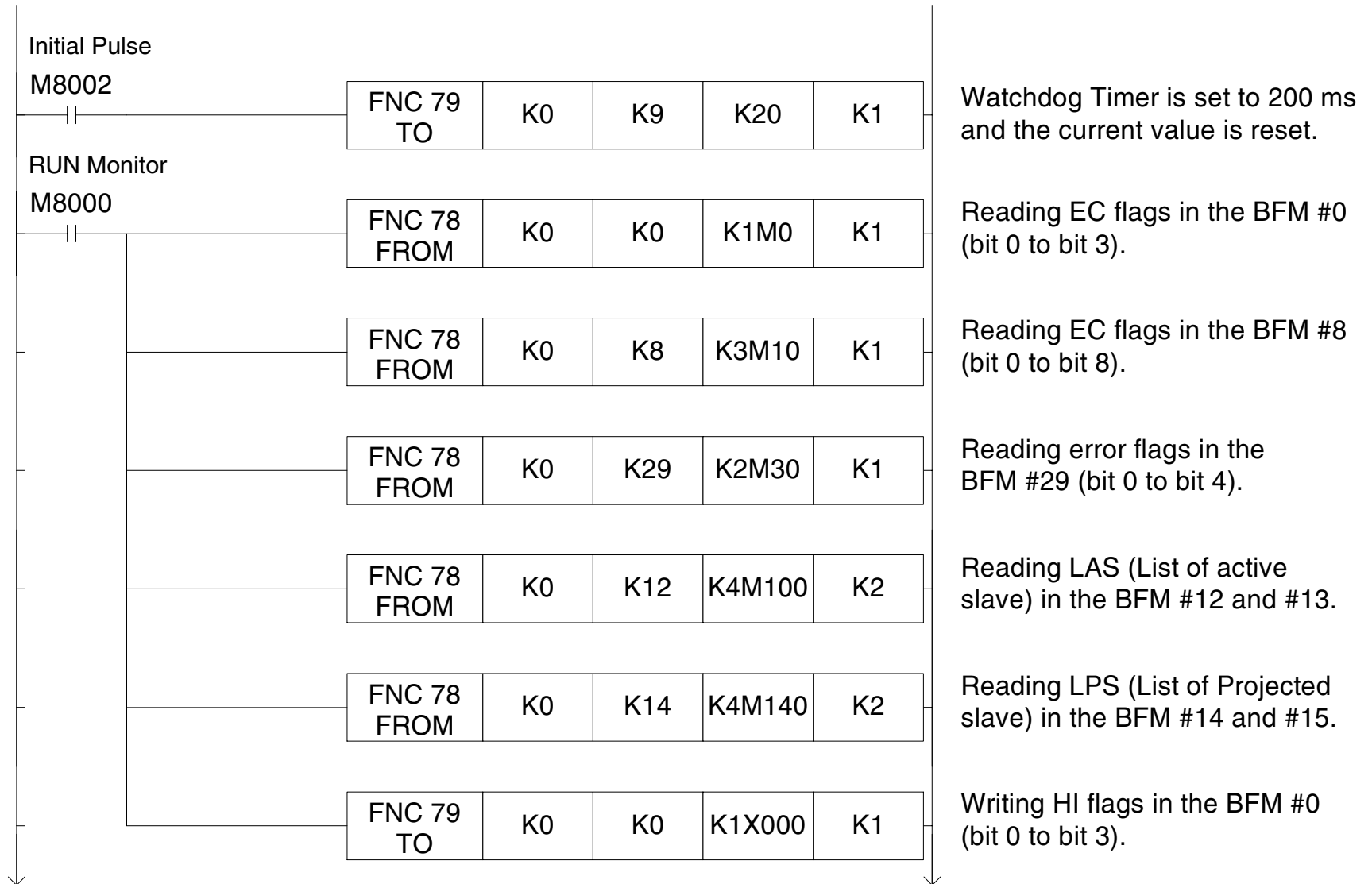

Continued.....

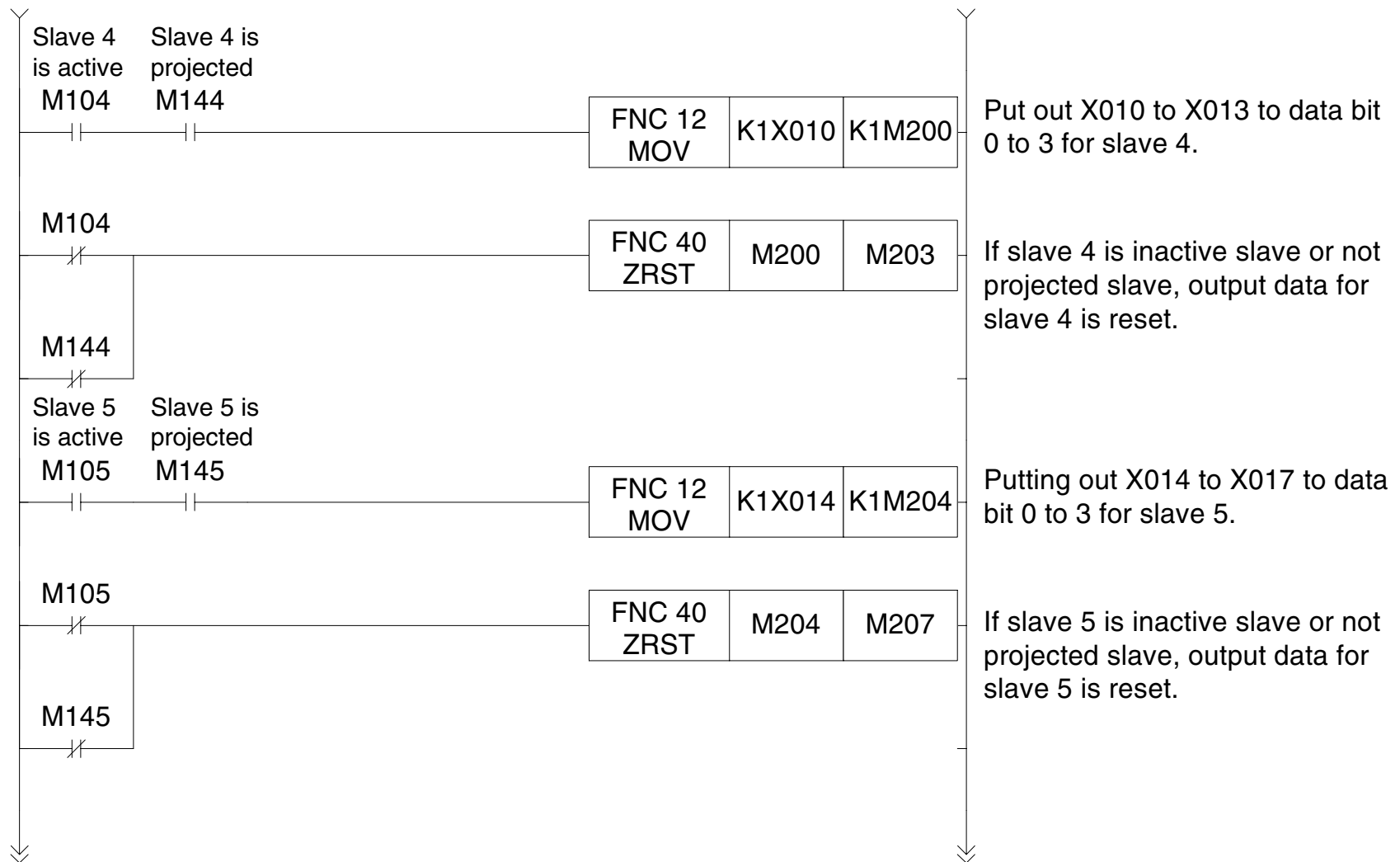

Continued.....



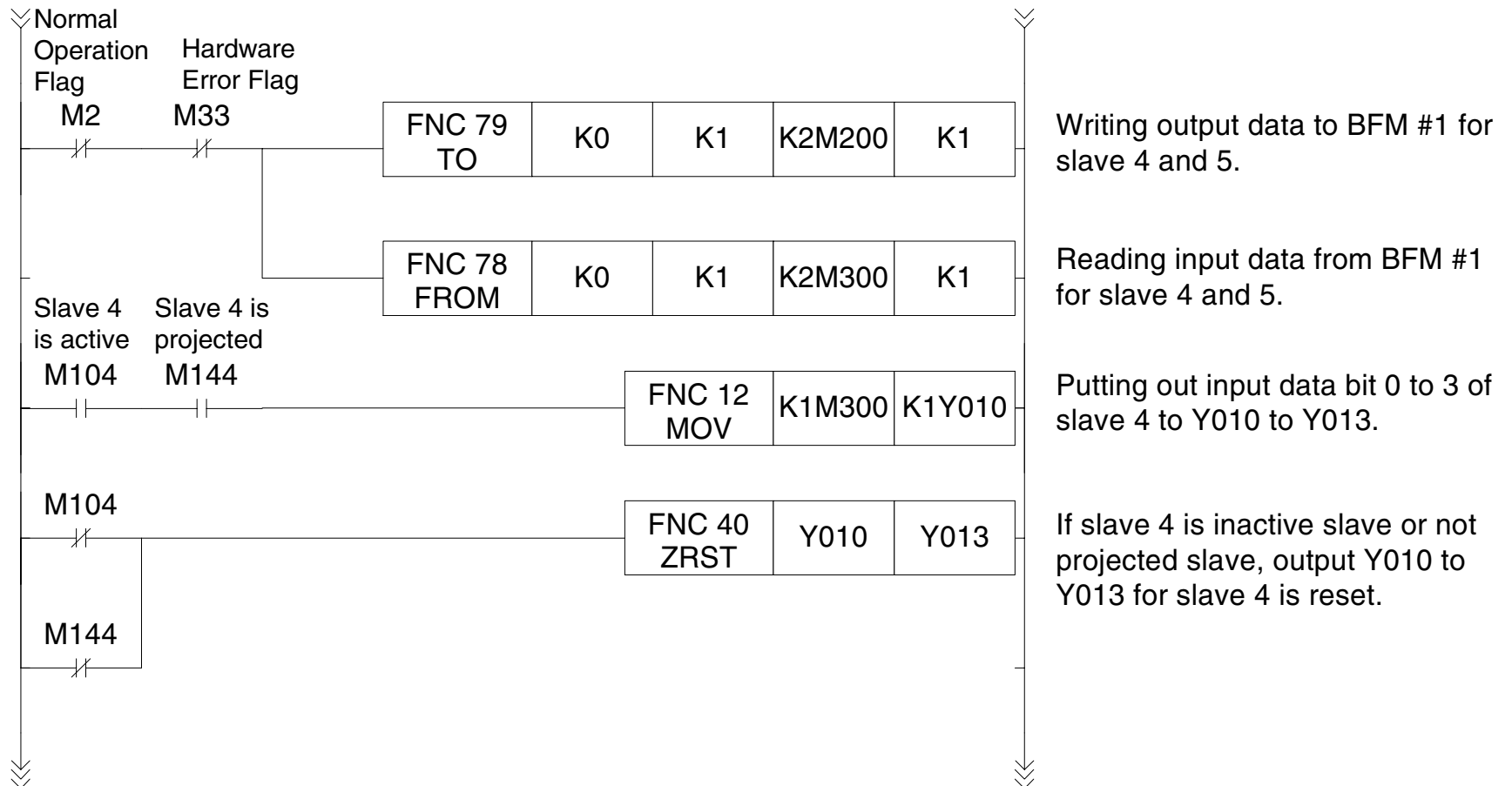

Continued.....

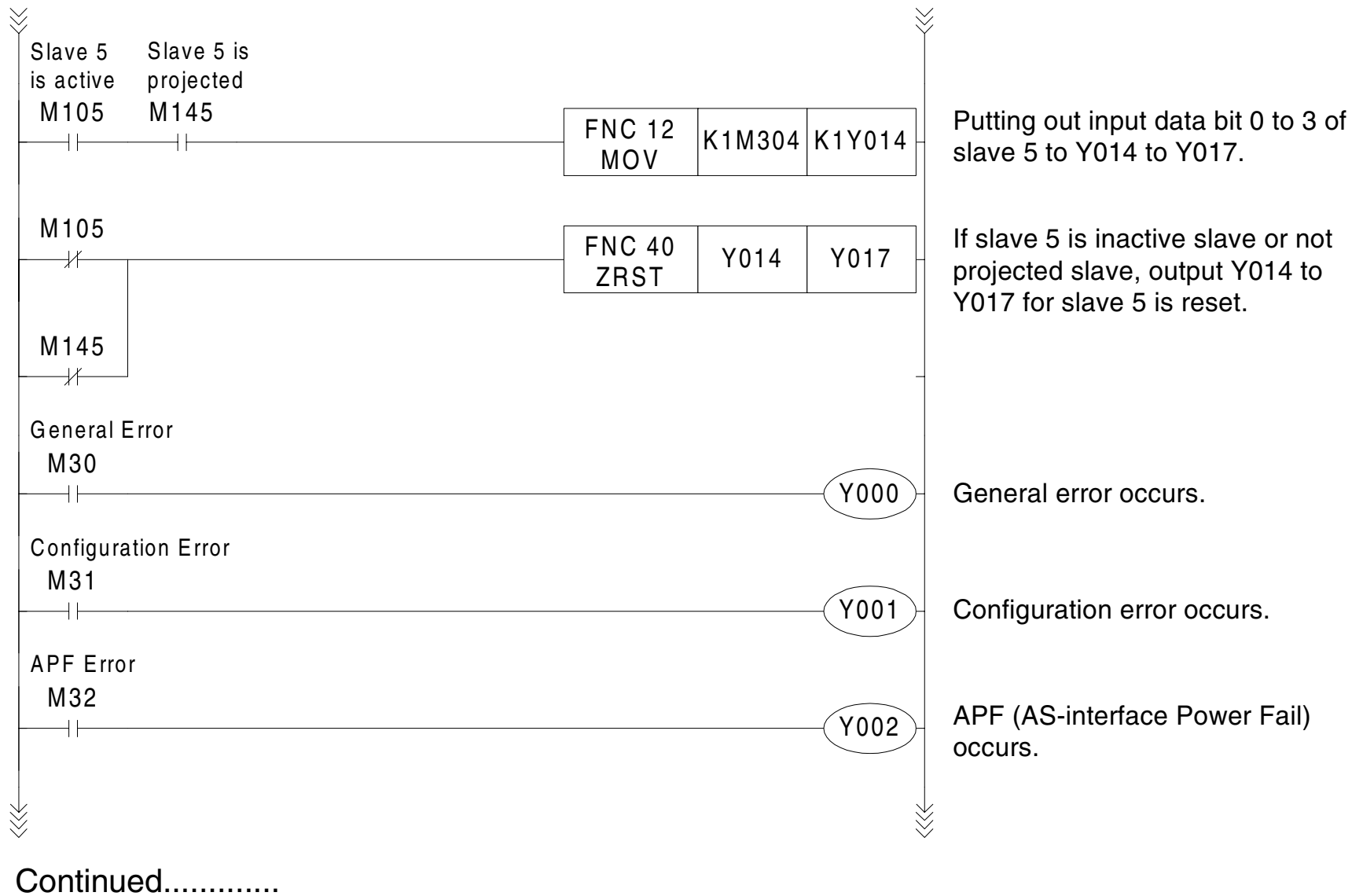

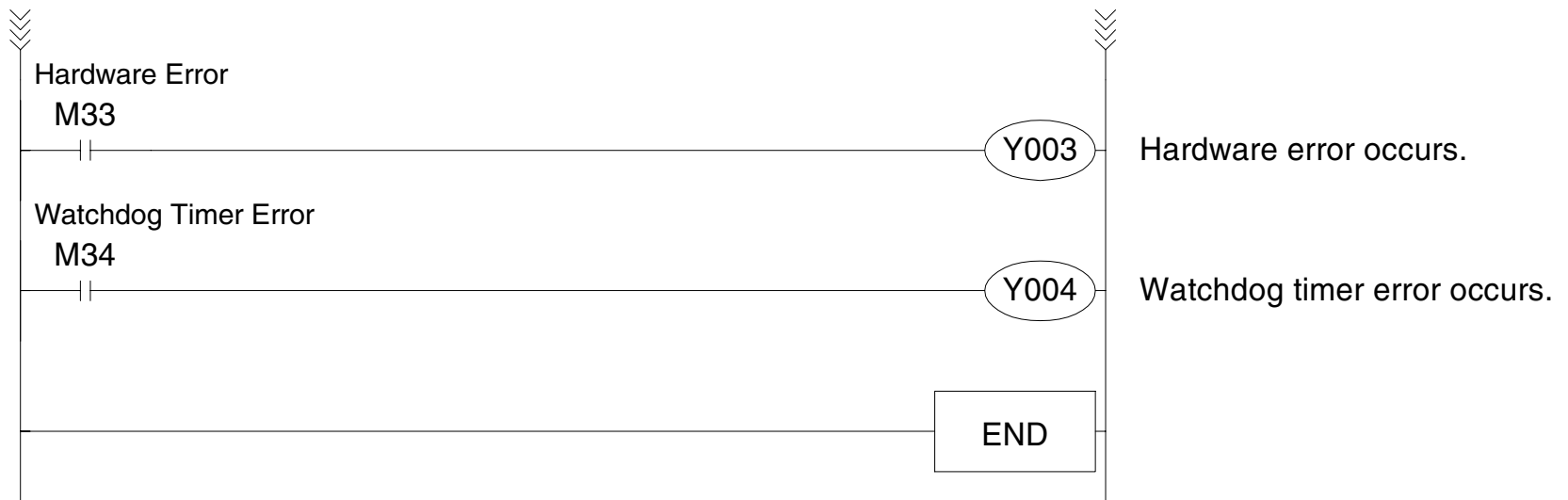

# MEMO

## 8. Diagnostics

### 8.1 Preliminary Checks

- 1) Check “POWER” and “U ASI” LED.
  - a) If “POWER” LED is OFF, check the connection of the 32ASI-M extension cable to the programmable controller.
  - b) If “U ASI” LED is OFF, check the current rating of AS-interface power supply, wiring and, total distance of system. For detail of total distance, refer to section 8.1 6).
- 2) Check the 24 V DC power supply for slave.

If whether this power supply capacity is not enough or miss-wiring is, the slave is not normal operation.
- 3) Check “ASI ACTIVE” and “CONFIG ERR” LED.
  - a) If “ASI ACTIVE” LED is OFF, check the wiring about the slave.
  - b) If “CONFIG ERR” LED is ON, check the wiring about the slave. And see section 8.2.
- 4) Check total slave number.

If total slave number is more than 31, please remove an unnecessary slave and adjust the number of total slaves to 31 or less.
- 5) Check whether it is an intended slave configuration.

If it is not so, please remake slave configuration.
- 6) Check total extension distance.

The total extension distance must not exceed 100m (328.1'). However, when the repeater is used, it is possible to extend by 100m repeater. Repeaters can be used up to two system.

## 8.2 Error Checking

If the 32ASI-M does not seem to operate normally, check the following items.

### 8.2.1 LED Check

Check the status of the LEDs for the 32ASI-M as follows.

- 1) Check the status of the “U ASI” LED.

**Table 8.1:U ASI LED check**

Status	Description
Lit.	AS-interface power supply is OK.
Otherwise	Check the wiring and capacity about AS-interface power supply.

- 2) Check the status of the “POWER” LED.

**Table 8.2:POWER LED check**

Status	Description
Lit.	The extension cable is properly connected. And 5 V DC is properly supplied from PLC.
Otherwise	Check the connection of the 32ASI-M extension cable to the PLC.

## 3) Check the status of the “CONFIG ERR” LED.

**Table 8.3: CONFIG ERR LED check**

Status	Description
OFF	Slave configuration status is OK.
Otherwise	Existing slave was lost or response was lost from slave, so that the mismatch occurred in LPS and LDS. Check the following points.

- Check the status of the slave. If the slave break, please replace the slave.
- Check the wiring for the slave. If the wire break, please exchange the cable.
- Check type of slave (permanent configuration of slave and actual configuration of slave). If type of slave is different type, please replace the slave, or please remake permanent configuration of slave.
- Please check this power supply if the AS-interface power supply after the repeater fails.

4) Check the status of other LEDs for the 32ASI-M as follows.

**Table 8.4: Other LEDs check**

LED Name	Status	
	ON	OFF
ASI ACTIVE	32ASI-M is in the normal operation.	32ASI-M is not in the normal operation.
PRJ MODE	32ASI-M is in the configuration mode.	32ASI-M is not in the configuration mode.
PRG ENABLE	Automatic address assignment enable (requirements of automatic address assignment is fulfilled.)	requirements of automatic address assignment is not fulfilled.
FROM / TO	BFM is accessed by FROM / TO instruction.	BFM is not accessed by FROM / TO instruction.



## 8.2.2 Check the display message for the 32ASI-M

**Table 8.5: Displayed Message Number**

No.	Description
0 to 31	Slave number
39	The last slave address which caused an configuration error is nothing
40	32ASI-M is in off-line phase
41	32ASI-M is in detection phase
42	32ASI-M is in activation phase
43	32ASI-M starts normal operation
70,72 to 76	Hardware error: Please contact a service representative.
80	Recognized slave address 0, 32ASI-M can not finish the configuration mode.
81	General error while changing a slave address
82	32ASI-M is set in the button operation prohibition from PLC.
88	32ASI-M is starting.
90	Error while changing a slave address in protected operating mode; No slave with address 0 present
91	Error while changing slave address; Target address is already occupied
92	Error while changing slave address; New address could not be set
93	Error while changing slave address; New address could only be stored volatile memory in the slave.

**Table 8.5: Displayed Message Number**

No.	Description
94	Error while changing a slave address in protected operating mode; Slave has wrong configuration information
95	Error while changing a slave address in protected operating mode; The address where the configuration error occurs is a slave of taking the place of a missing slave.

## 8.2.3 Check BFM #29 error status of the 32ASI-M

Table 8.6: Error Status BFM #29

Bit No.	Description	0(OFF)	1(ON)	Check Points
Bit 0	General Error	No general error	This bit is ON if one or more error bits (1 to 4) are ON.	Check Bit 1 to 4 in BFM #29.
Bit 1	Config_OK	No configuration error	Configuration error occurs	Check whether wiring is correct or LPS is the same as LDS. For detail, refer to section 8.2.
Bit 2	APF	APO (AS-interface Power On)	APF (AS-interface Power Fail)	Check the current rating of AS-interface power supply, wiring and, total distance of system. For detail of total distance, refer to section 8.1 6).
Bit 3	Hardware Error	No hardware error detected	Hardware error occurs	Please contact a service representative.
Bit 4	Watchdog Error	No watchdog error	Watchdog error occurs	See section 5.4
Bit 5 to 15	Reserved			

# MEMO

## Appendix A: Further Information Manual Lists

**Table A-1: Further Information Manual Lists**

Manual name	Manual No.	Description
FX <sub>3U</sub> Series User's Manual - Hardware Edition	JY997D16501	This manual explains the wiring, installation and specification for FX <sub>3U</sub> Series programmable controller.
FX <sub>3UC</sub> Series User's Manual - Hardware Edition	JY997D28701	This manual explains the wiring, installation and specification for FX <sub>3UC</sub> Series programmable controller.
FX <sub>2N</sub> Series Programmable Controllers Hardware Manual	JY992D66301	This manual explains the wiring, installation and specification, etc. about FX <sub>2N</sub> Series programmable controller.
FX <sub>1N</sub> Series Programmable Controllers Hardware Manual	JY992D89301	This manual explains the for wiring, installation and specification, etc. about FX <sub>1N</sub> Series programmable controller.
FX <sub>0</sub> /FX <sub>0N</sub> Series Programmable Controllers Hardware Manual	JY992D47501	This manual explains the for wiring, installation and specification, etc. about FX <sub>0</sub> and FX <sub>0N</sub> Series programmable controllers.
FX <sub>3U</sub> /FX <sub>3UC</sub> Series Programming Manual - Basic & Applied Instruction Edition	JY997D16601	This manual explains the instructios for FX <sub>3U</sub> /FX <sub>3UC</sub> Series programmable controller.

**Table A-1: Further Information Manual Lists**

Manual name	Manual No.	Description
FX Series Programmable controllers Programming Manual II	JY992D88101	This manual explains the instructions for FX <sub>1S</sub> , FX <sub>1N</sub> , FX <sub>2N</sub> and FX <sub>2NC</sub> Series programmable controller.
FX Series Programmable controllers Programming Manual	JY992D48301	This manual explains the instructions for the FX <sub>0</sub> , FX <sub>0S</sub> , FX <sub>0N</sub> , FX and FX <sub>2C</sub> Series programmable controllers.



# USER'S MANUAL

FX<sub>2</sub>N-32ASI-M AS-interface Master Block



HEAD OFFICE: TOKYO BUILDING, 2-7-3 MARUNOUCHI, CHIYODA-KU, TOKYO 100-8310, JAPAN  
HIMEJI WORKS:840, CHIYODA CHO, HIMEJI, JAPAN

---

JY992D76901G  
(MEE)

Effective Sep. 2007  
Specifications are subject  
to change without notice.